

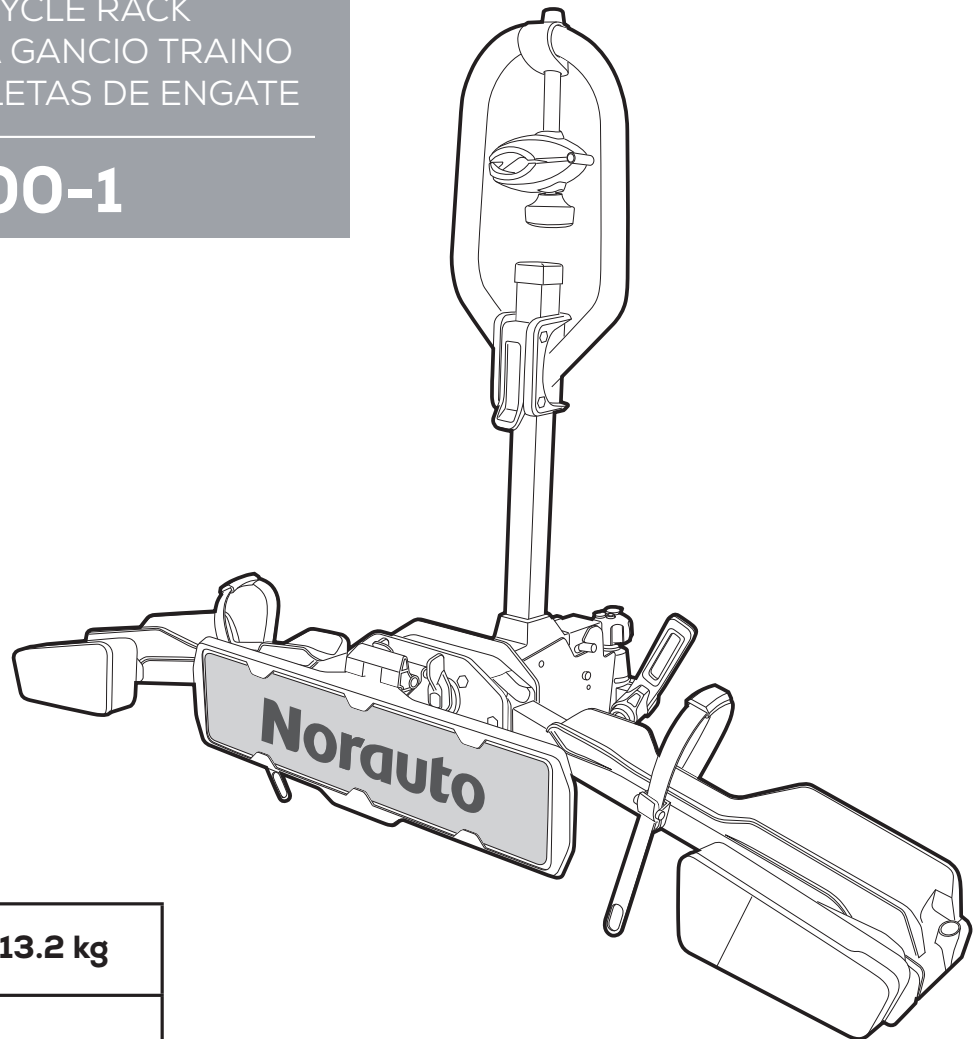



Norauto

PORTE-VÉLOS D'ATTELAGE
FIETSDRAGER VOOR OP
TREKHAAK
FAHRRADHECKTRÄGER
ANHÄNGERKUPPLUNG
PROTABICICLETAS DE
ENGANCHE
TOWABLE BICYCLE RACK
PORTABICI DA GANCIO TRAINO
PORTA-BICICLETAS DE ENGATE

E-FIT 200-1

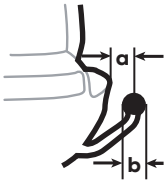

	13.2 kg
	a: >65mm b: Ø50mm
	MAX 1x30 kg

Lisez impérativement le manuel d'utilisation avant toute utilisation du produit.
De handleiding verplicht lezen voor elke ingebruikname
Vor der Verwendung des Produkts ist diese Bedienungsanleitung aufmerksam durchzulesen.
Es esencial leer el manual antes de usar el producto.
It is essential to read the manual before use.
È essenziale leggere il manuale prima dell'uso.
Leia o manual do utilizador antes de utilizar o produto.

ART: 2390965/NO1022

FR - Notice d'utilisation / **NL** - Gebruiksaanwijzing
DE - Bedienungsanleitung / **ES** - Instrucciones
EN - User manual / **IT** - Istruzioni per l'uso
PT - Instruções de utilização





**PIÈCES / WISSELSTUKKEN / TEILE / PIEZAS / PARTS/
PEZZI / PEÇAS**

x1

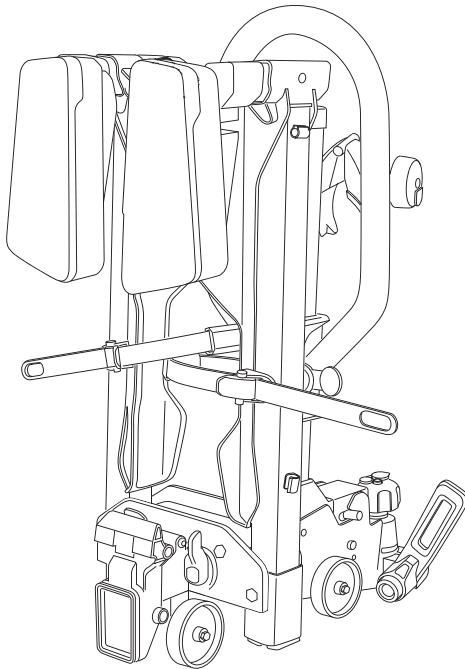

x1

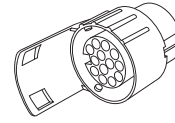

x1



x1

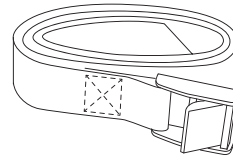

x1

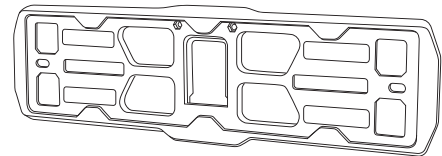

**ASSEMBLAGE DU PORTE-VÉLOS / DE PRODUCTIE VAN DE FIETSENDRAGER
MONTAGE DES FAHRRADTRÄGERS / ENSAMBLAJE DEL PORTABICIS
ASSEMBLY OF THE BICYCLE RACK / ASSEMBLAGGIO DEL PORTABICICI
MONTAGEM DO PORTA-BICILETAS**

1

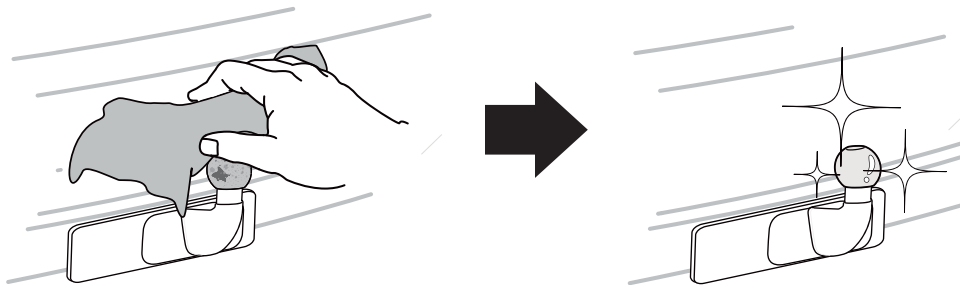

2

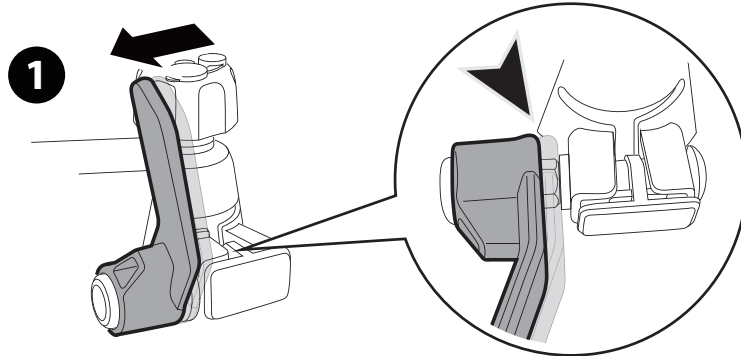
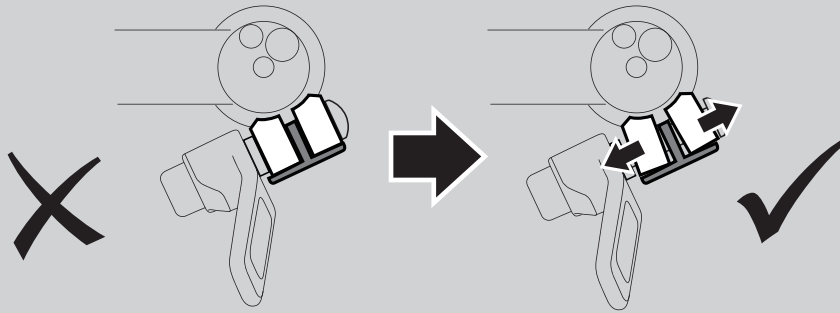

3

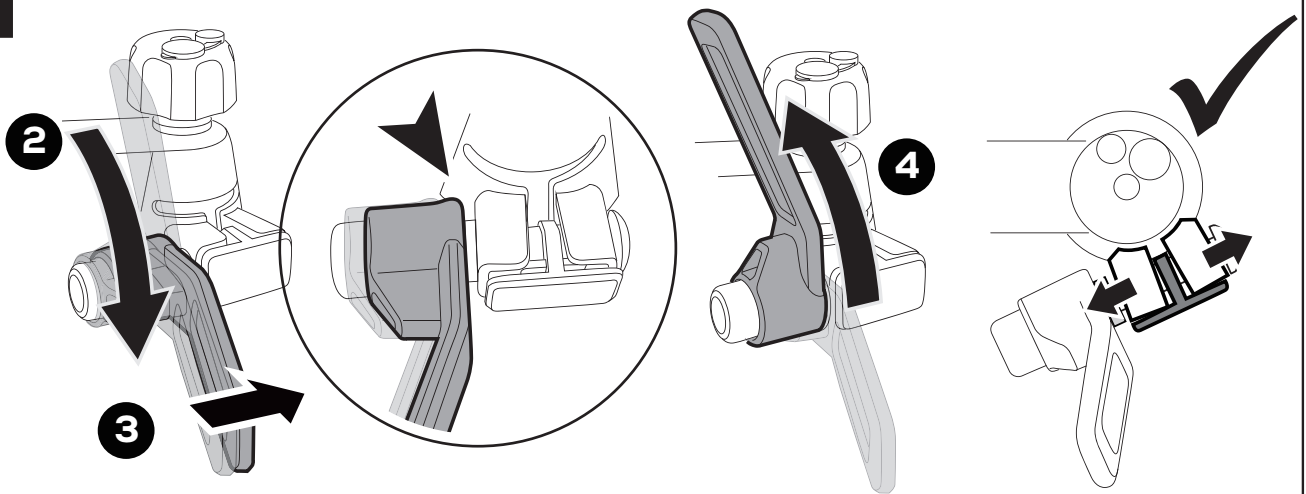

4

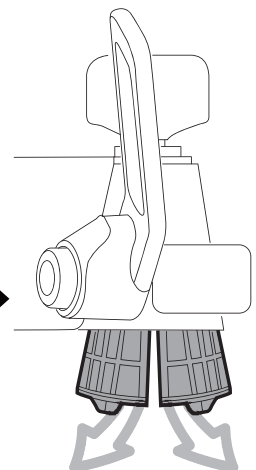
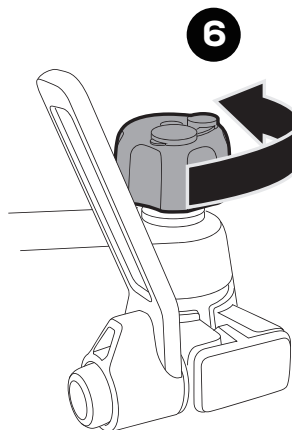
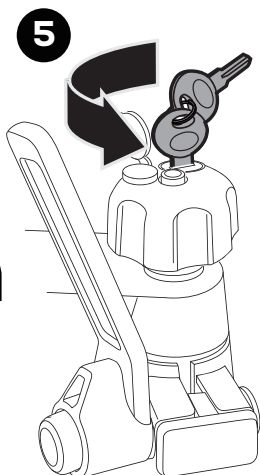
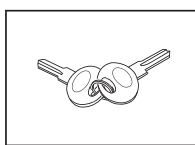

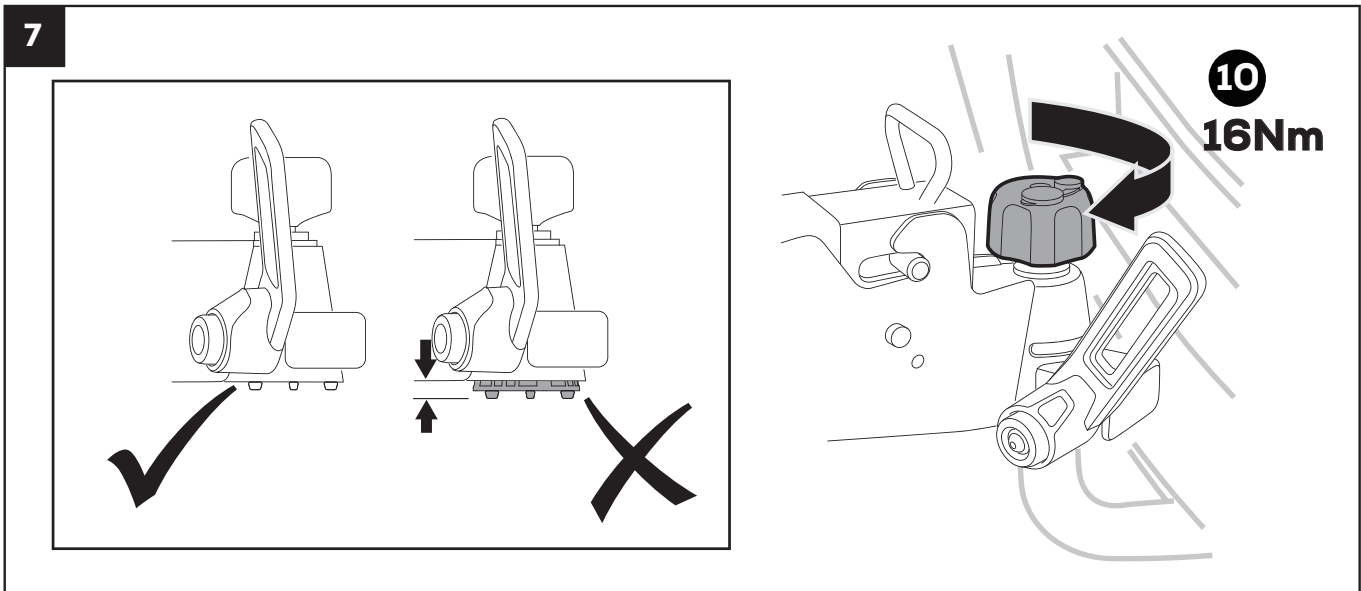
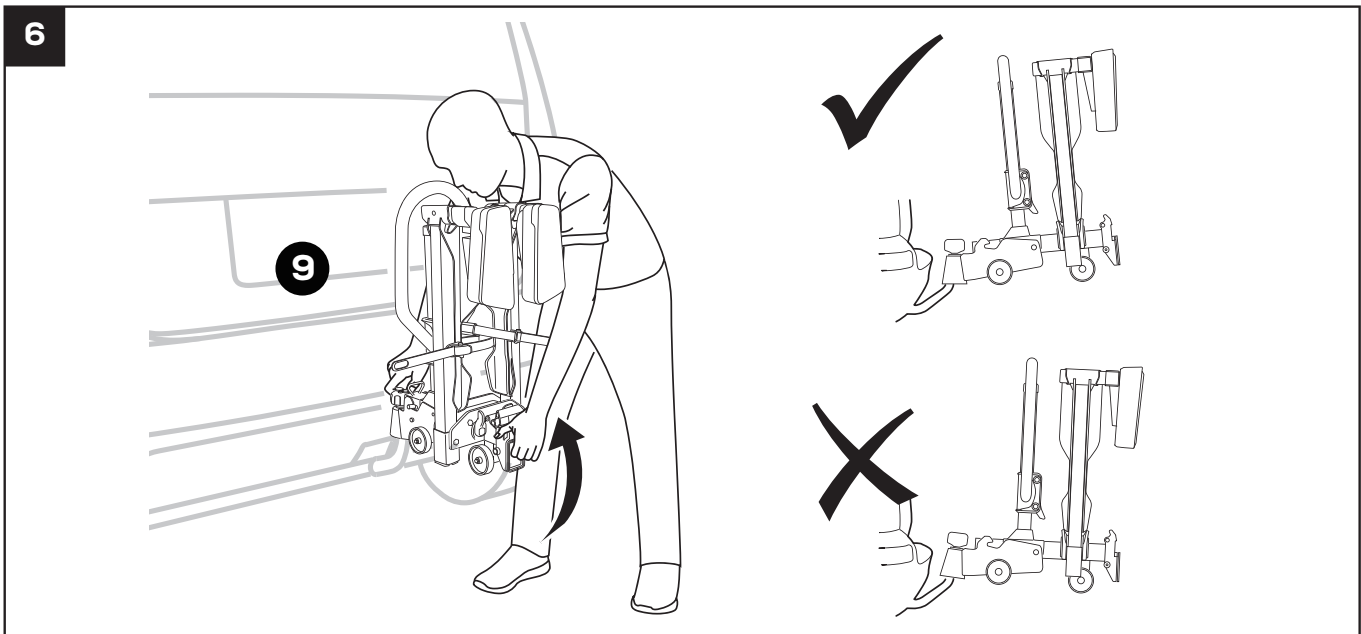
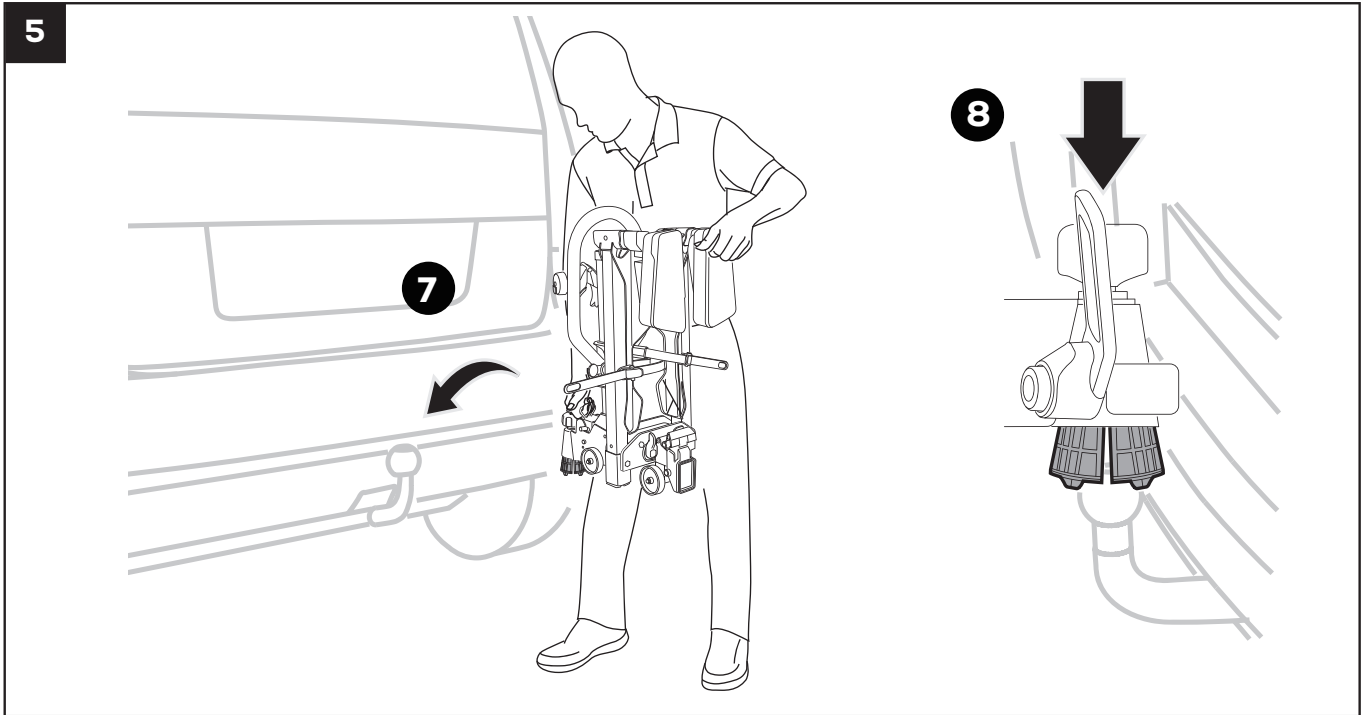

8

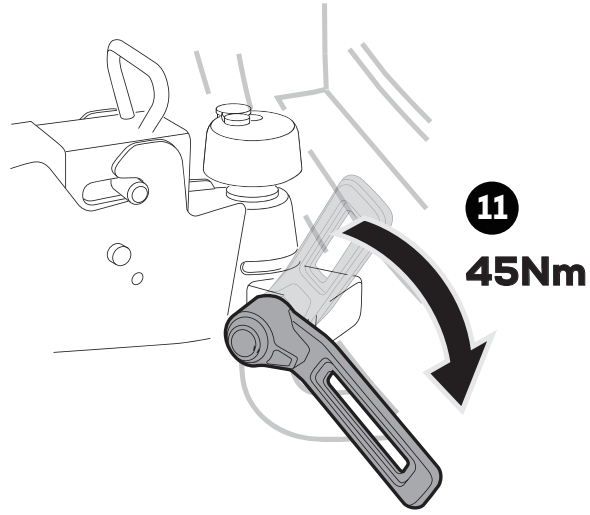

9

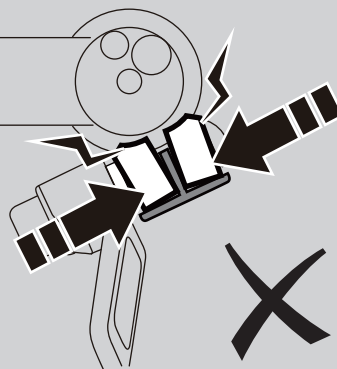
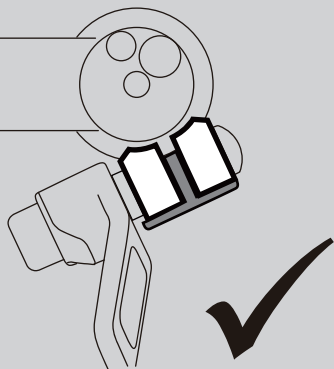
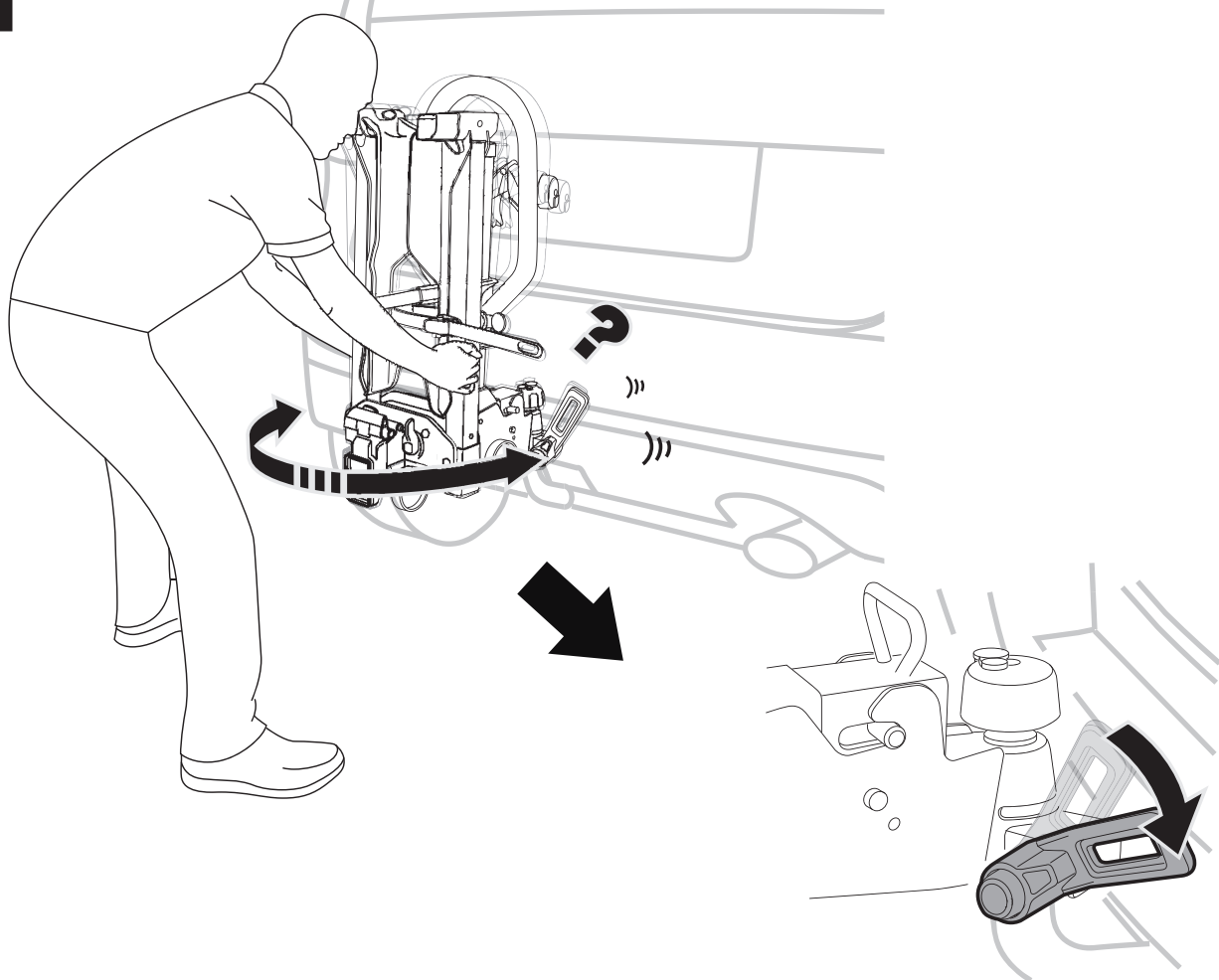

10

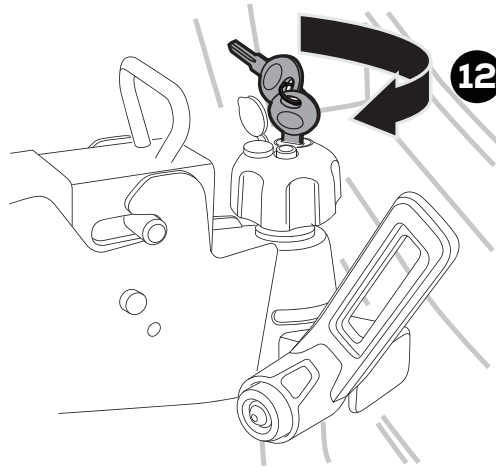
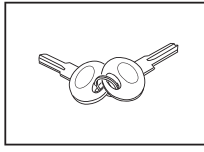

12

11

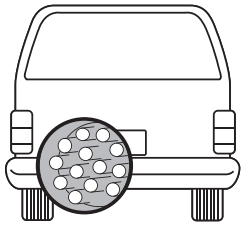

13-pin

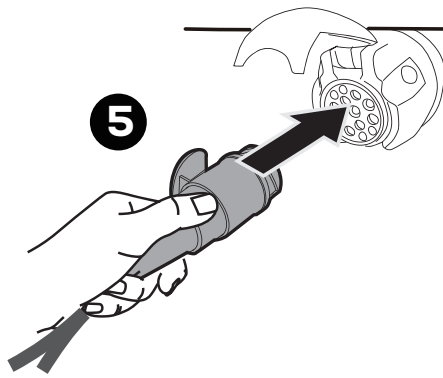

5

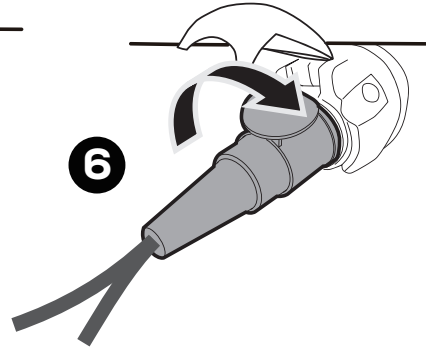

6

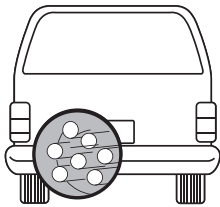

7-pin

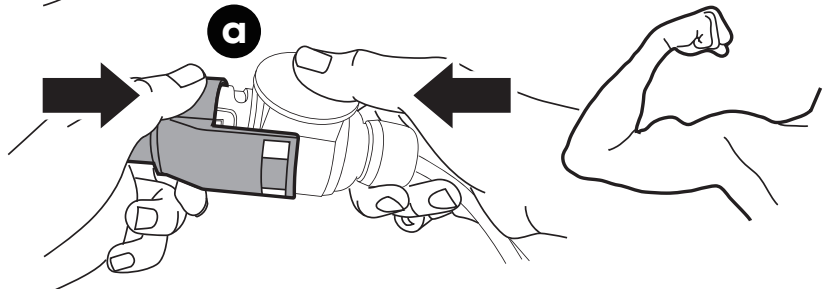
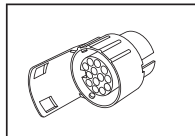
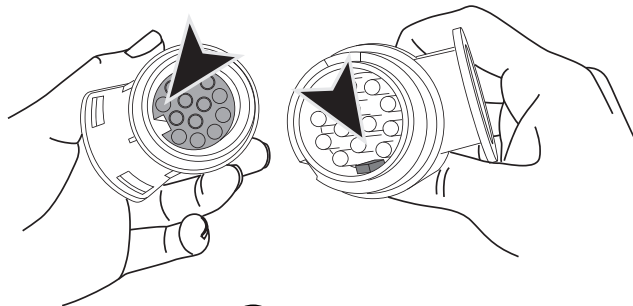

a

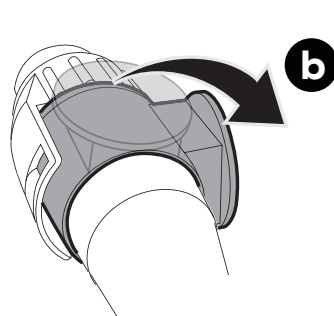

b

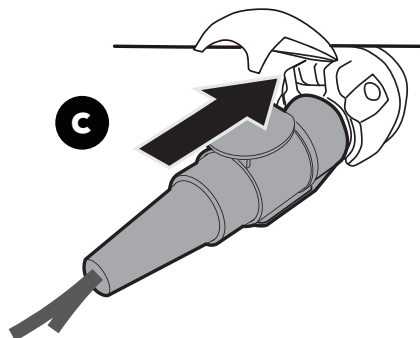

c

12

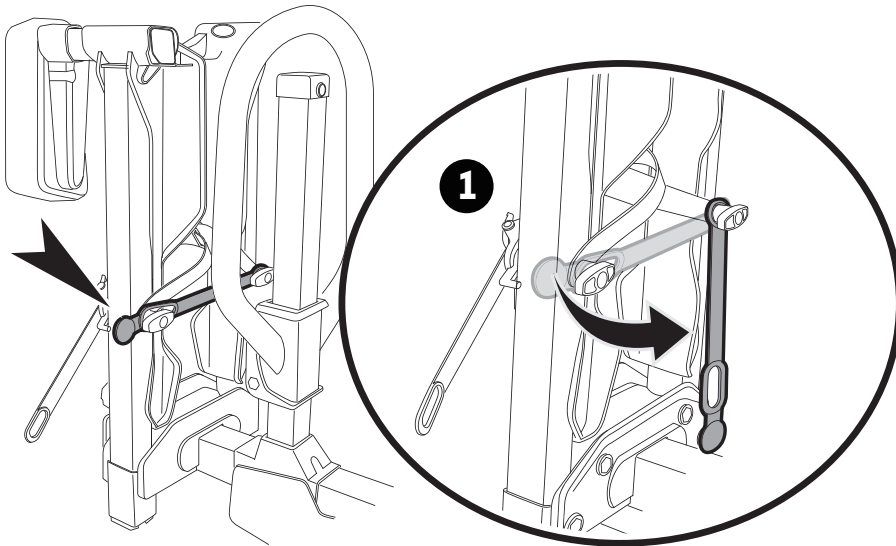

13

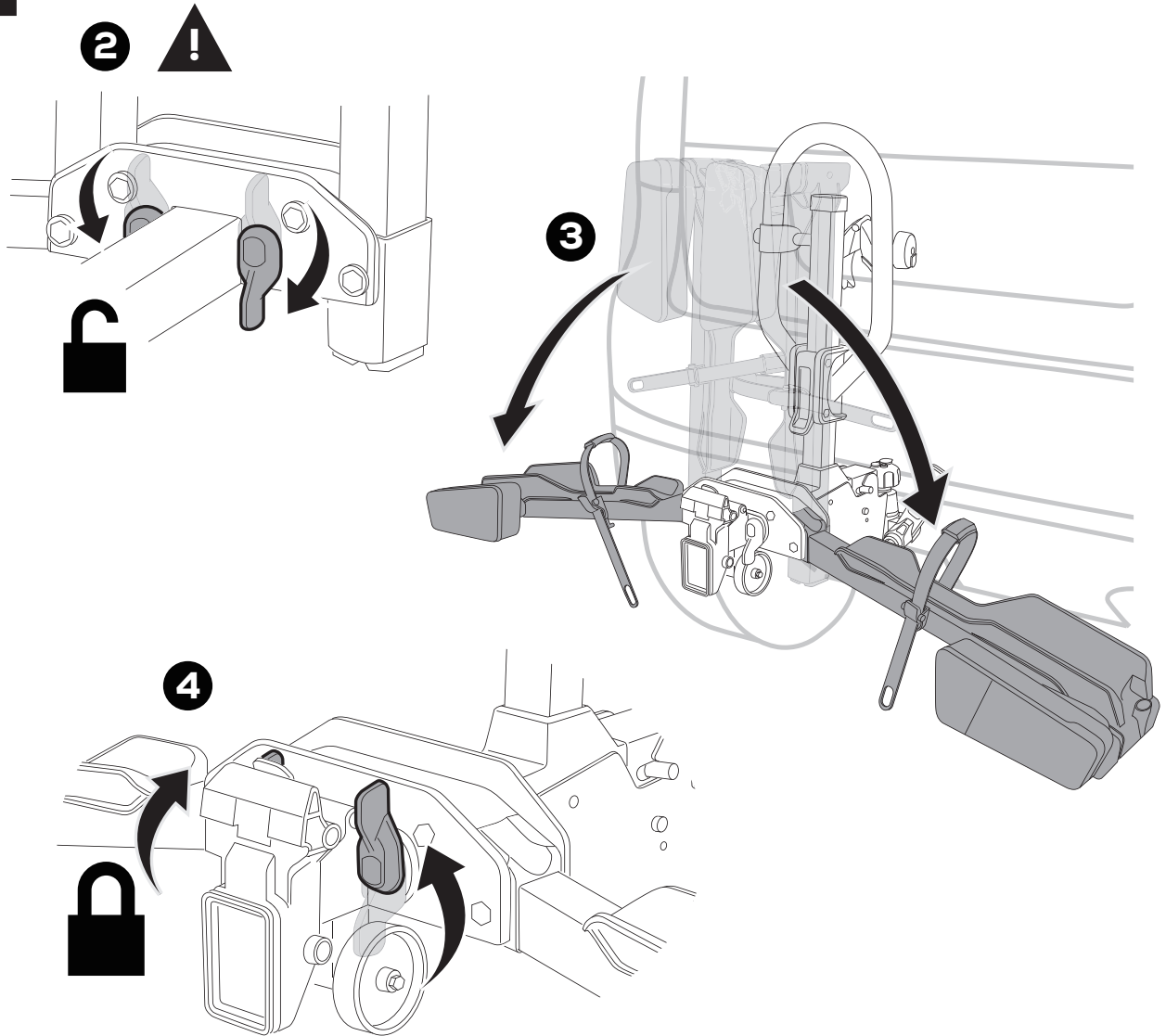

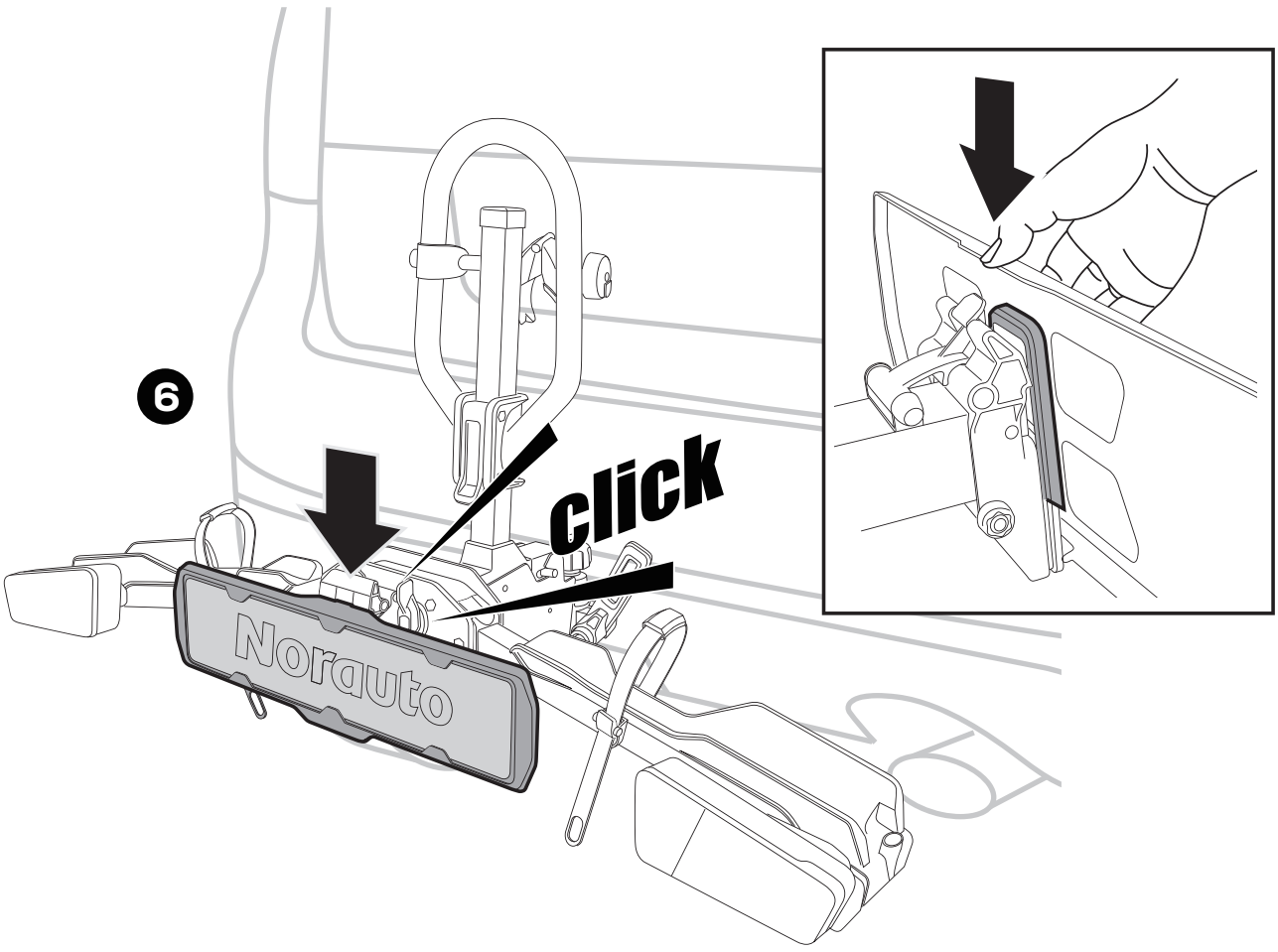
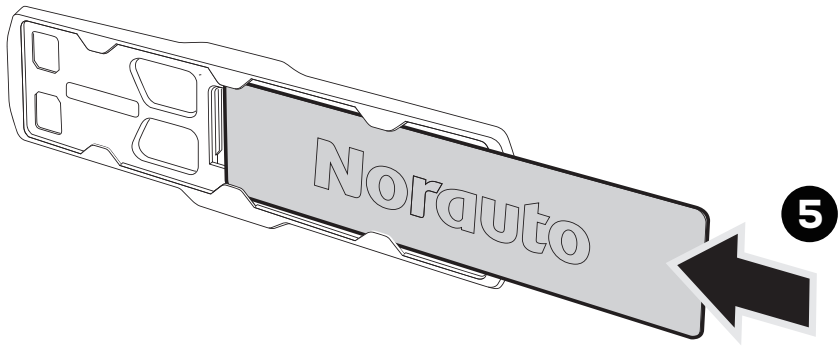

MONTAGE DES VÉLOS / MONTAGE VAN DE FIETSEN
MONTAGE DER FAHRRÄDER / MONTAJE DE LAS BICICLETAS
BICYCLES MOUNTING/ MONTAGGIO DELLE BICI
MONTAGEM DAS BICICLETAS

1

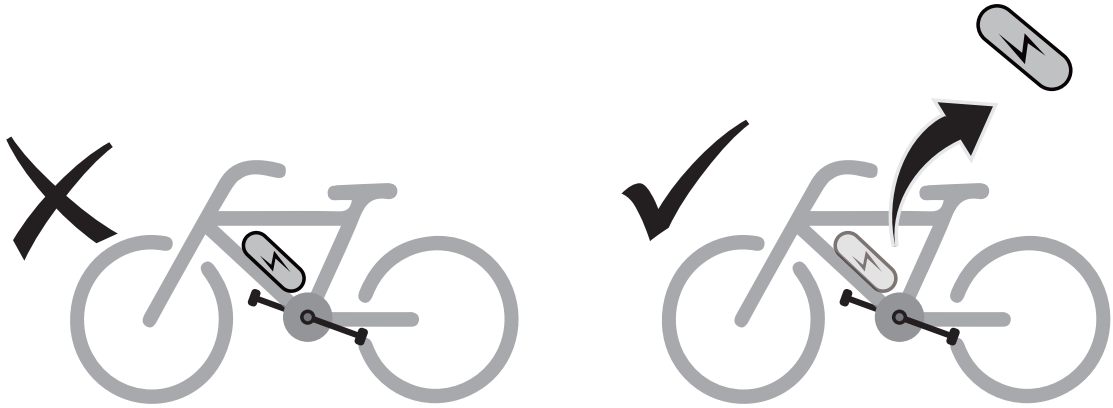

2



1 x 30kg = MAX
30 kg

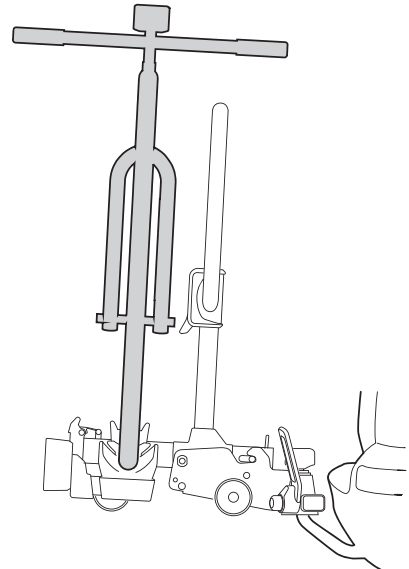

3

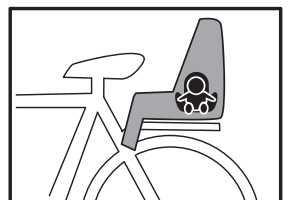
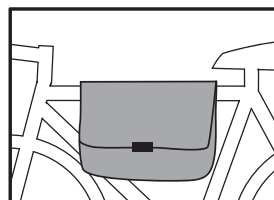
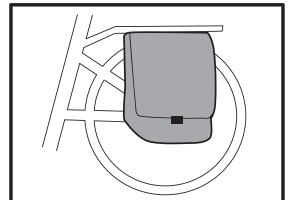
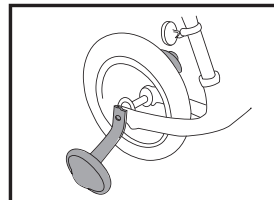
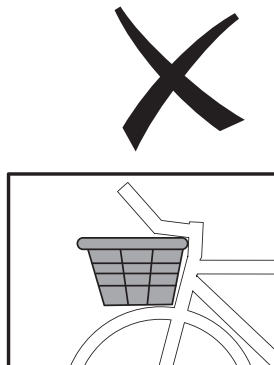
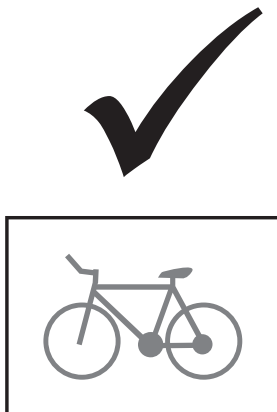

4

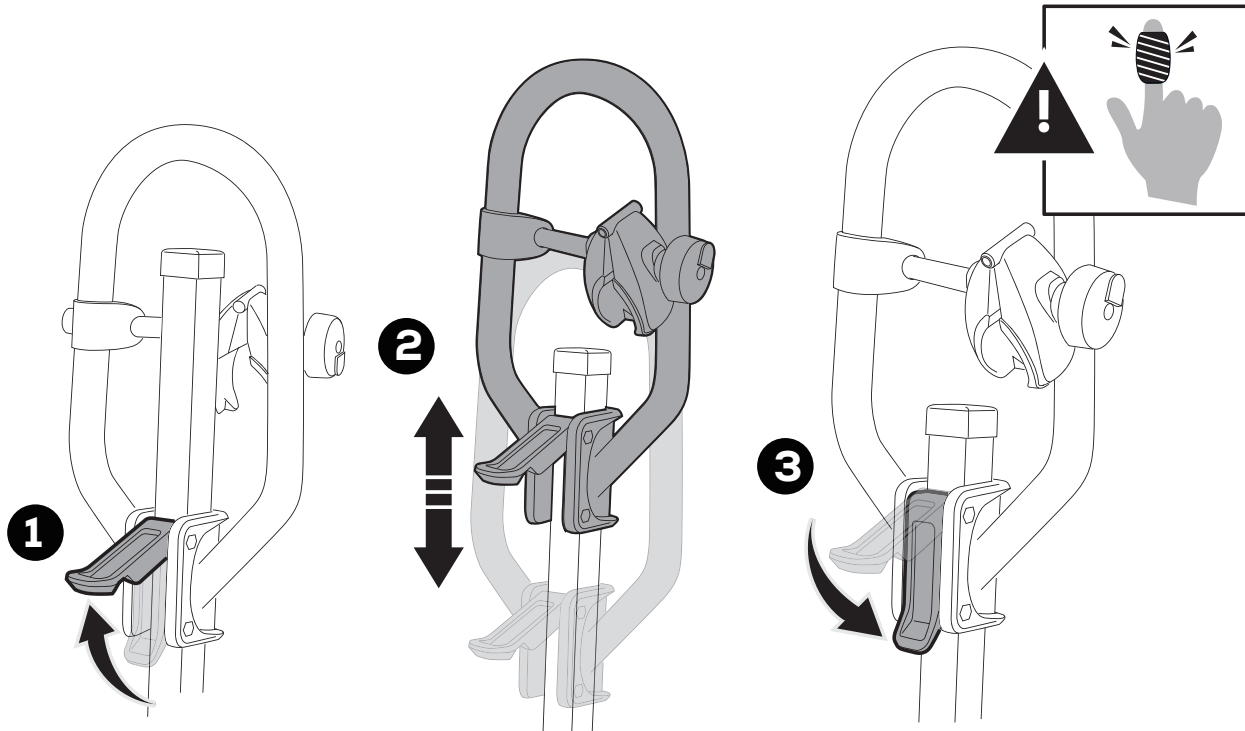

5

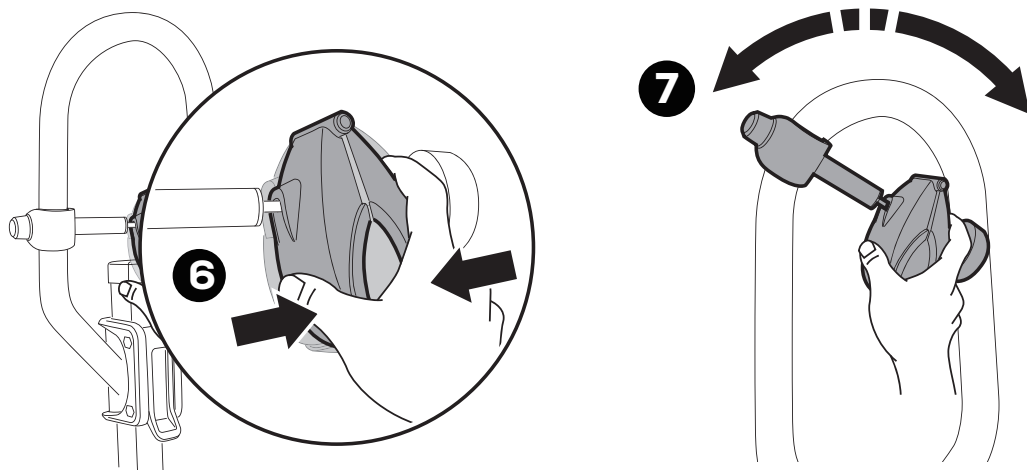
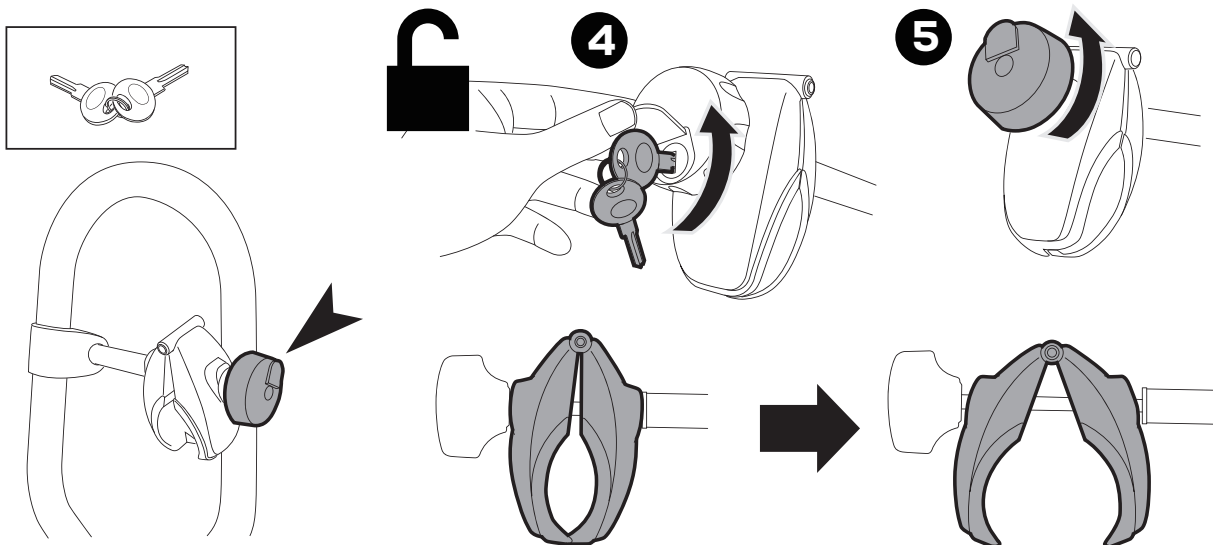

6

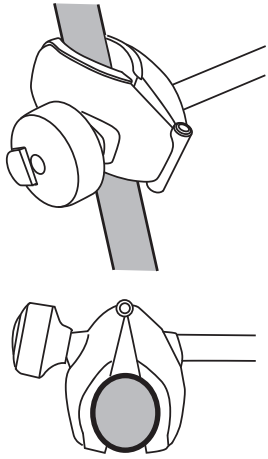

min. Ø25 mm
max. Ø50 mm

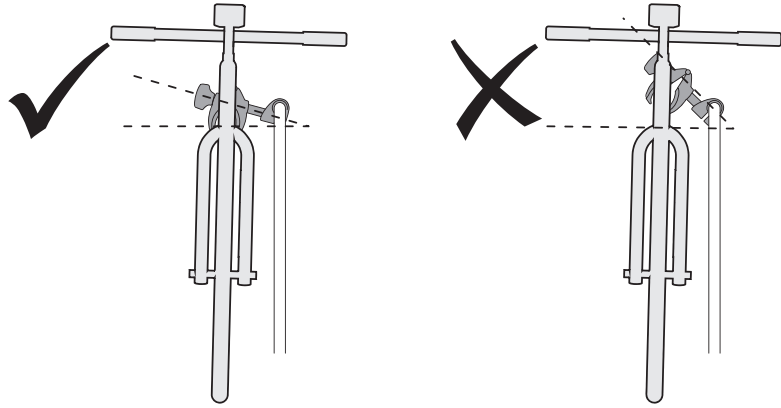
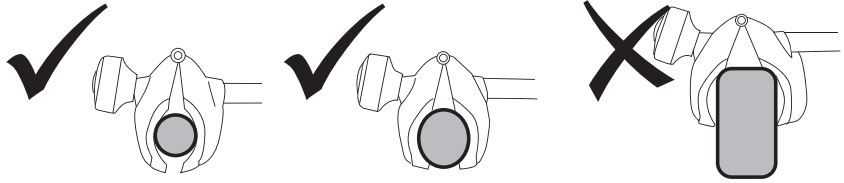

7

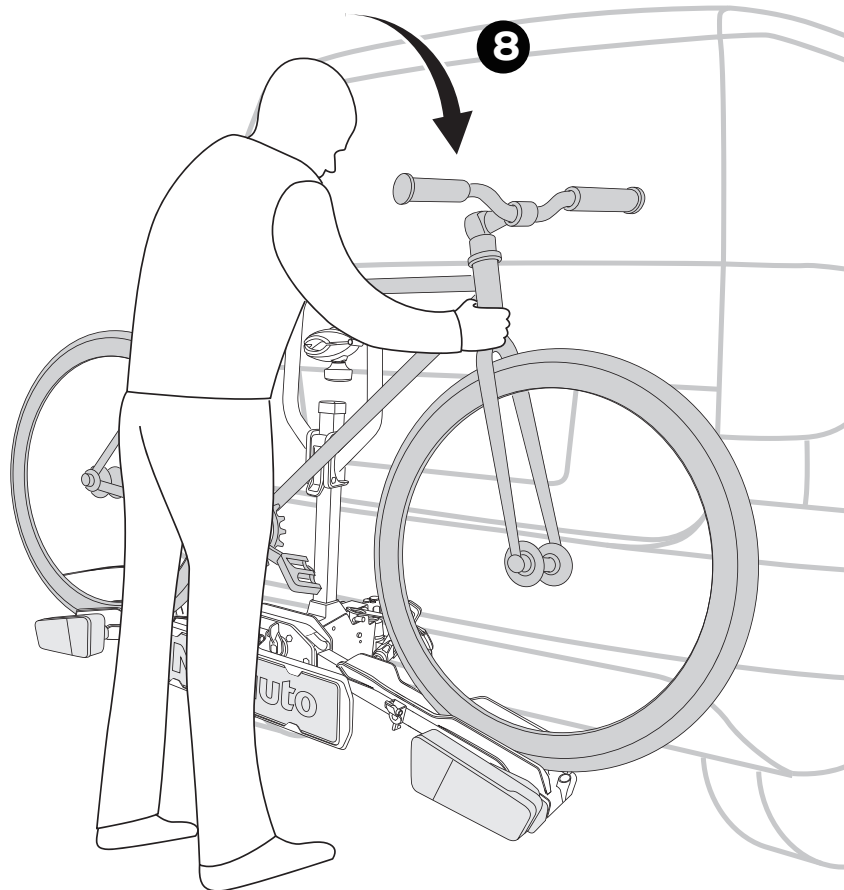

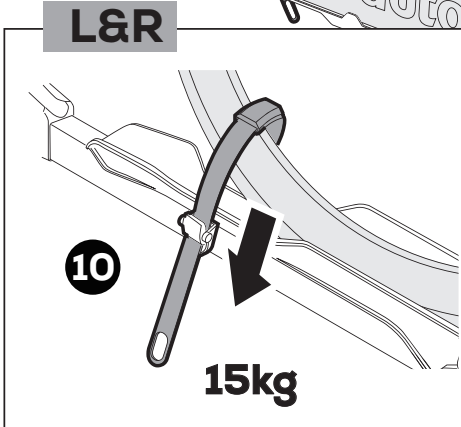
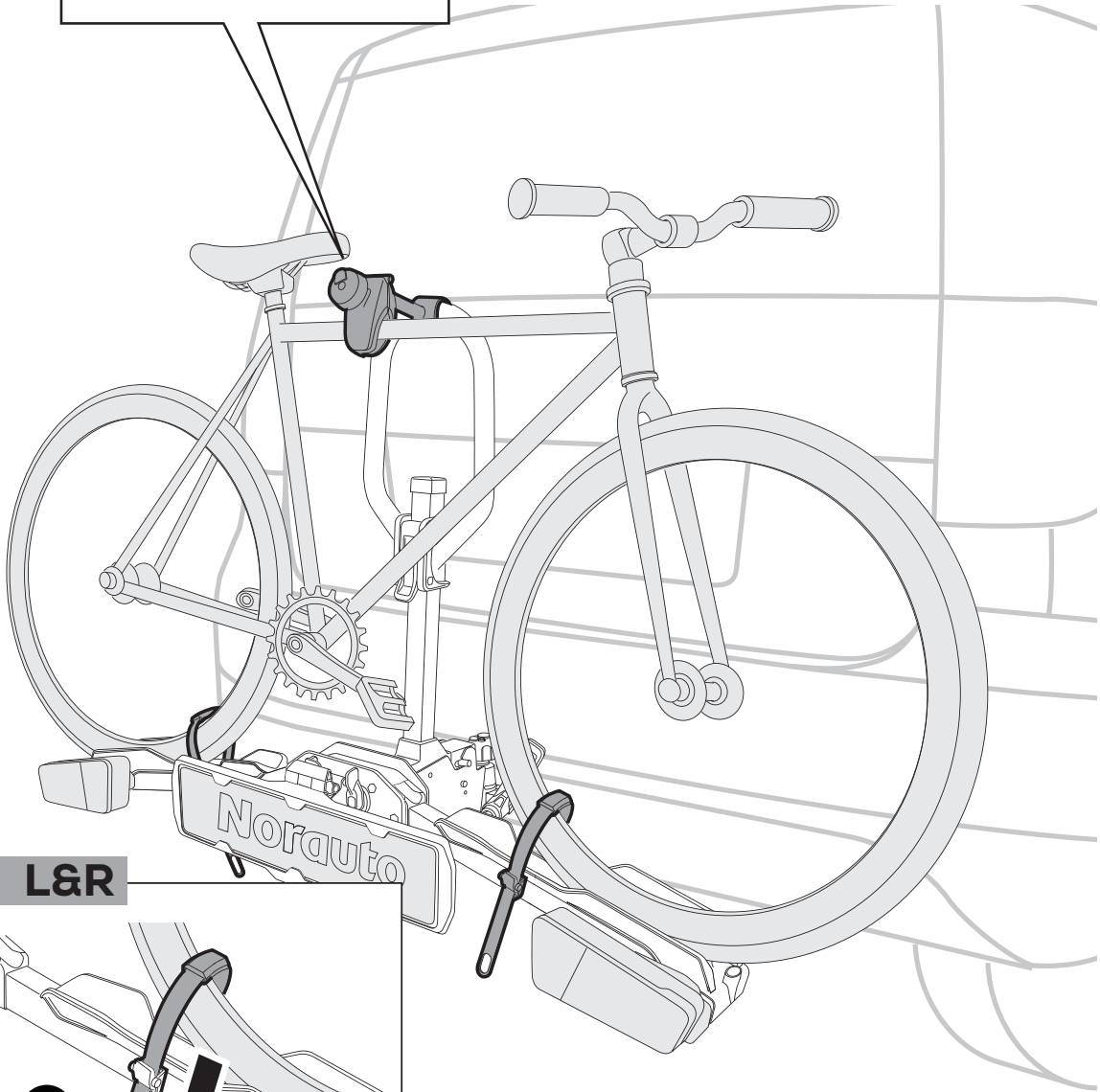
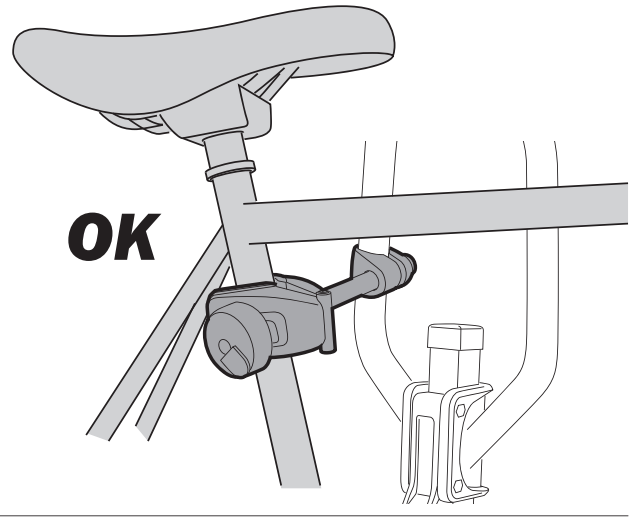
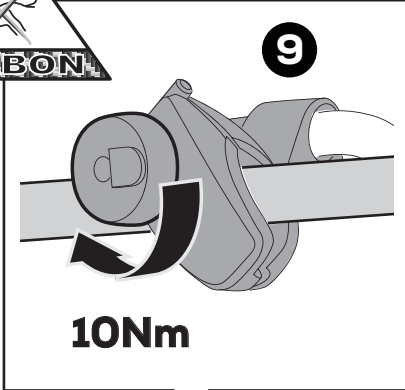

9

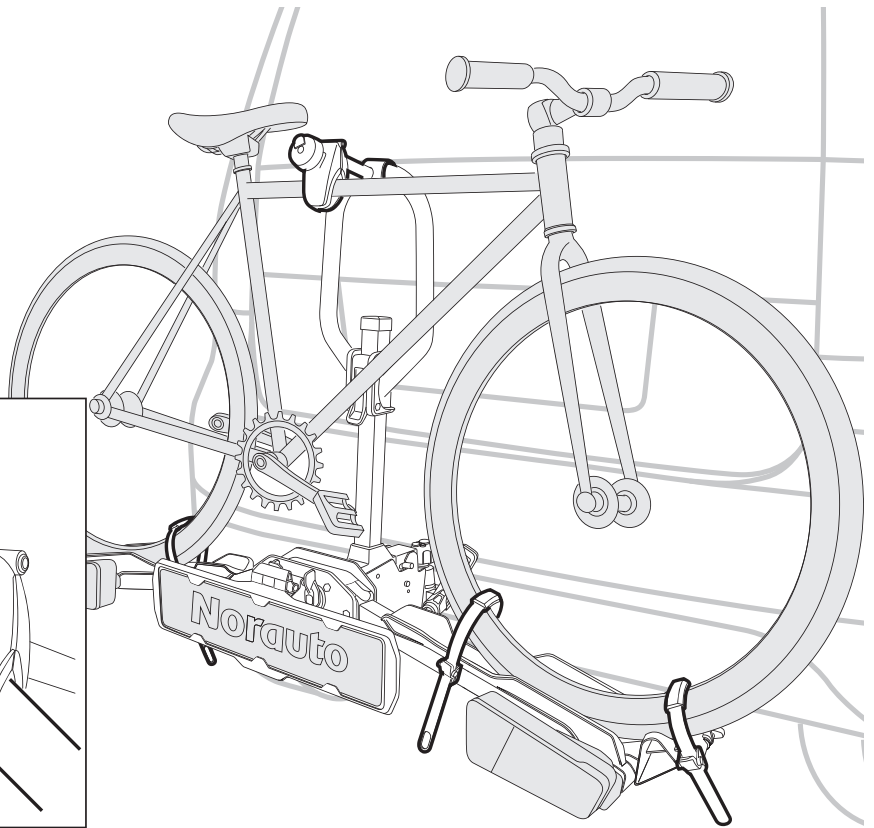
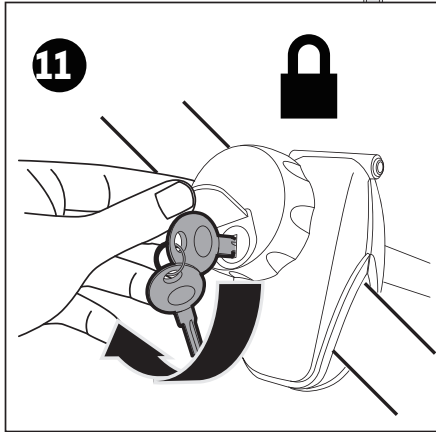
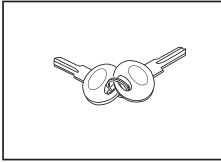

10

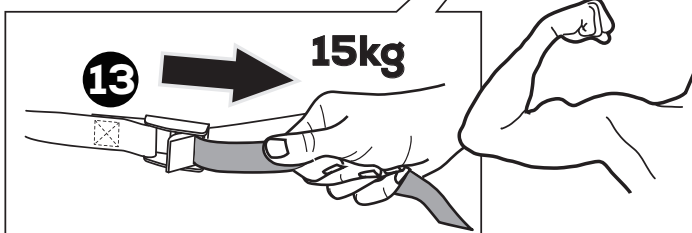
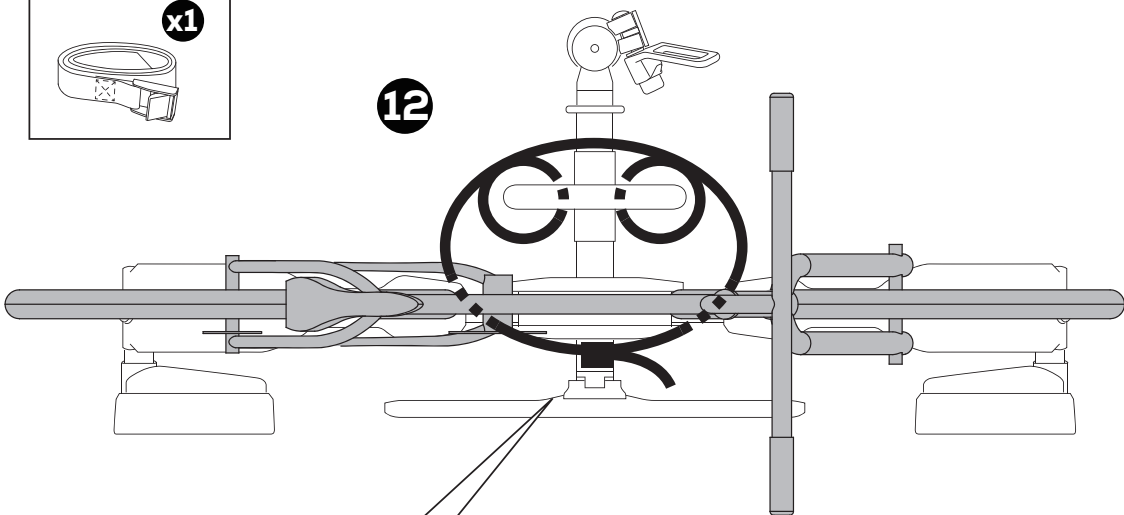

BASCULEMENT DU PORTE-VÉLOS POUR UN ACCES AU COFFRE
KANTELEN VAN DE FIETSENDRAGER OM TOEGANG TE HEBBEN TOT DE KOFFER
ABKLAPPEN DES FAHRRADTRÄGERS ZUM ÖFFNEN DES KOFFERRAUMS
EL PORTABICIS BASCULA PARA PODER ACCEDER AL MALETERO
TILTING OF THE BICYCLE RACK FOR AN EASY ACCESS TO THE TRUNK
PORTABICI BASCULANTE PER ACCEDERE AL BAULE
BASCULAR O PORTA BICICLETAS PARA ACEDER Á MALA

1

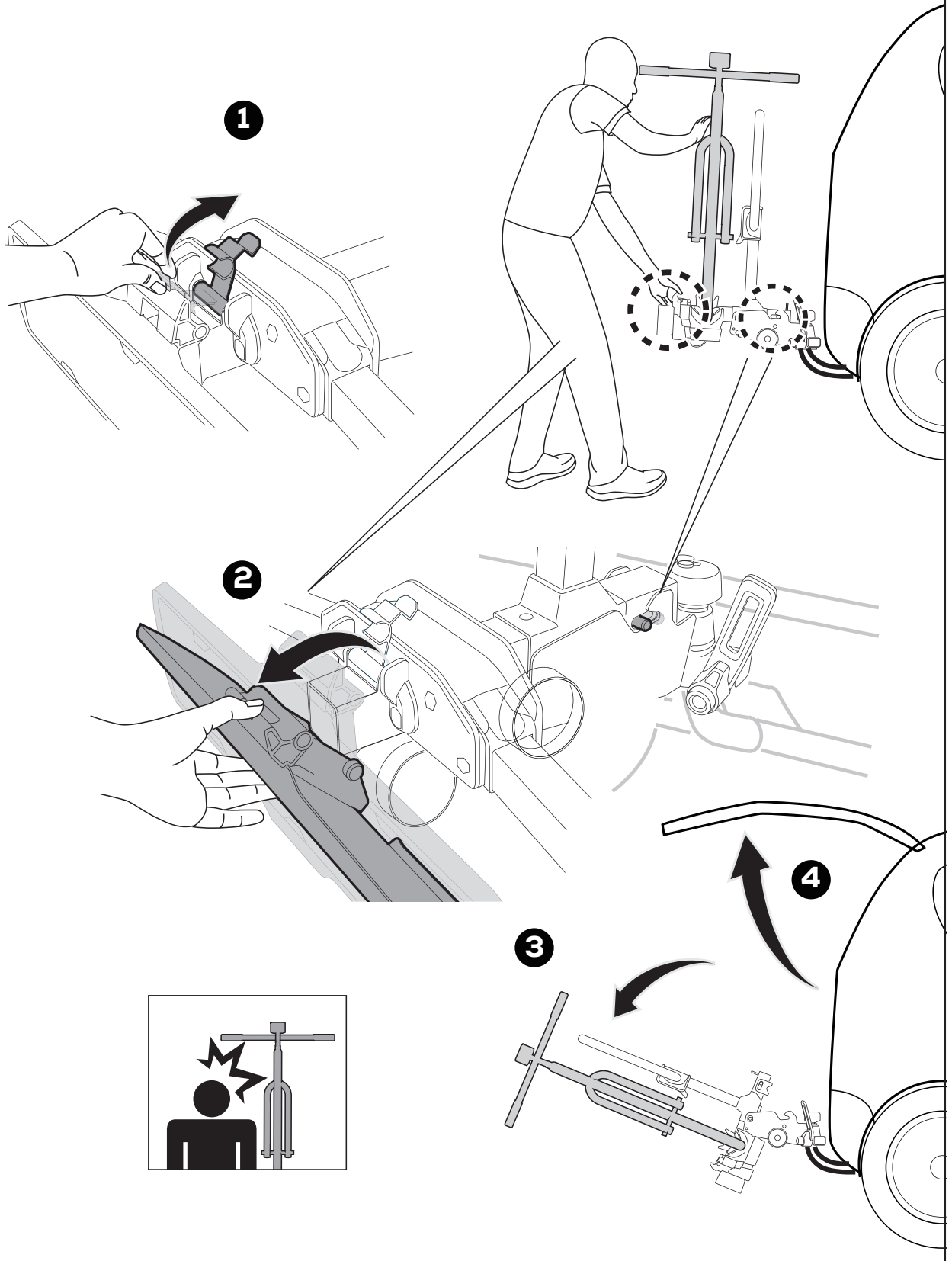

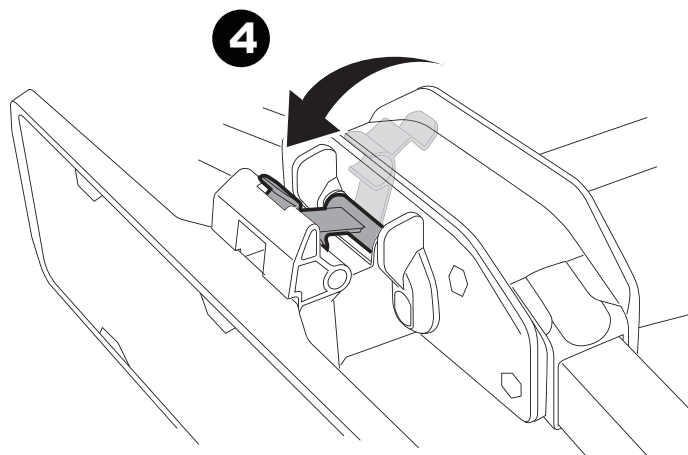
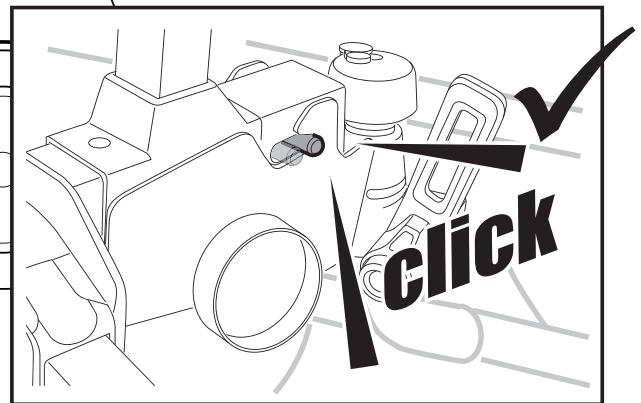
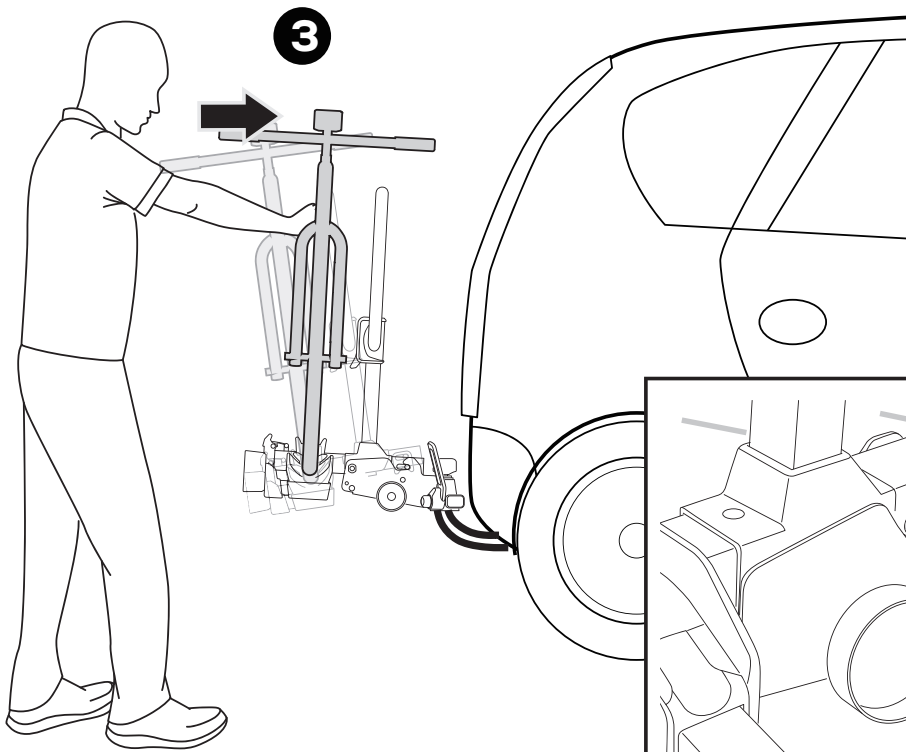
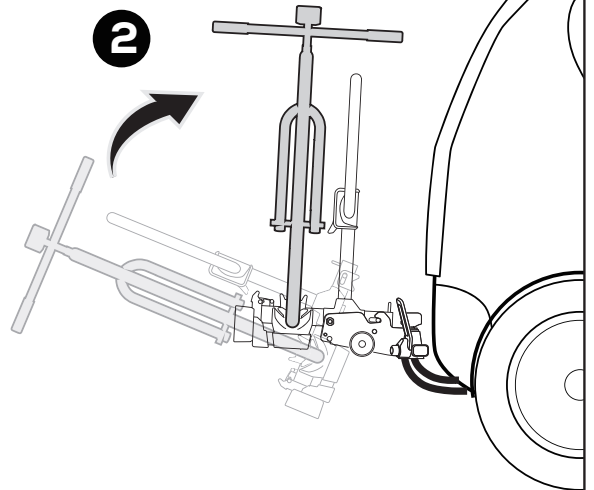
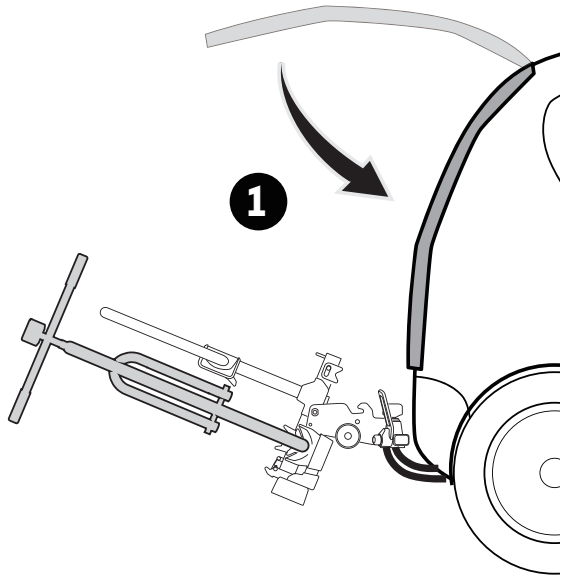

DEMONTAGE / ABMONTIEREN / DESMONTAJE / DISASSEMBLY
SMONTAGGIO / DESMONTAGEM

1

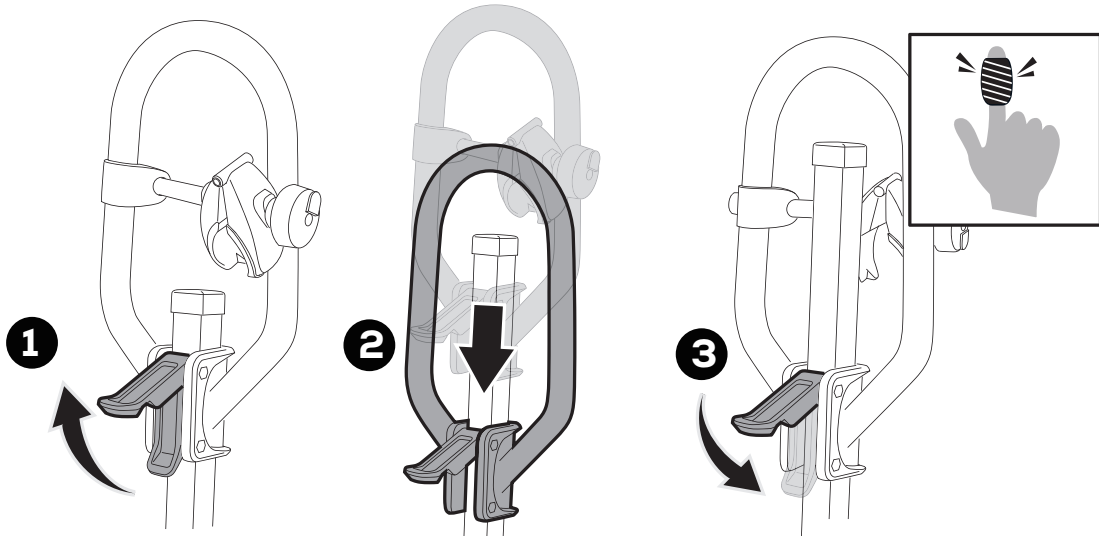

2

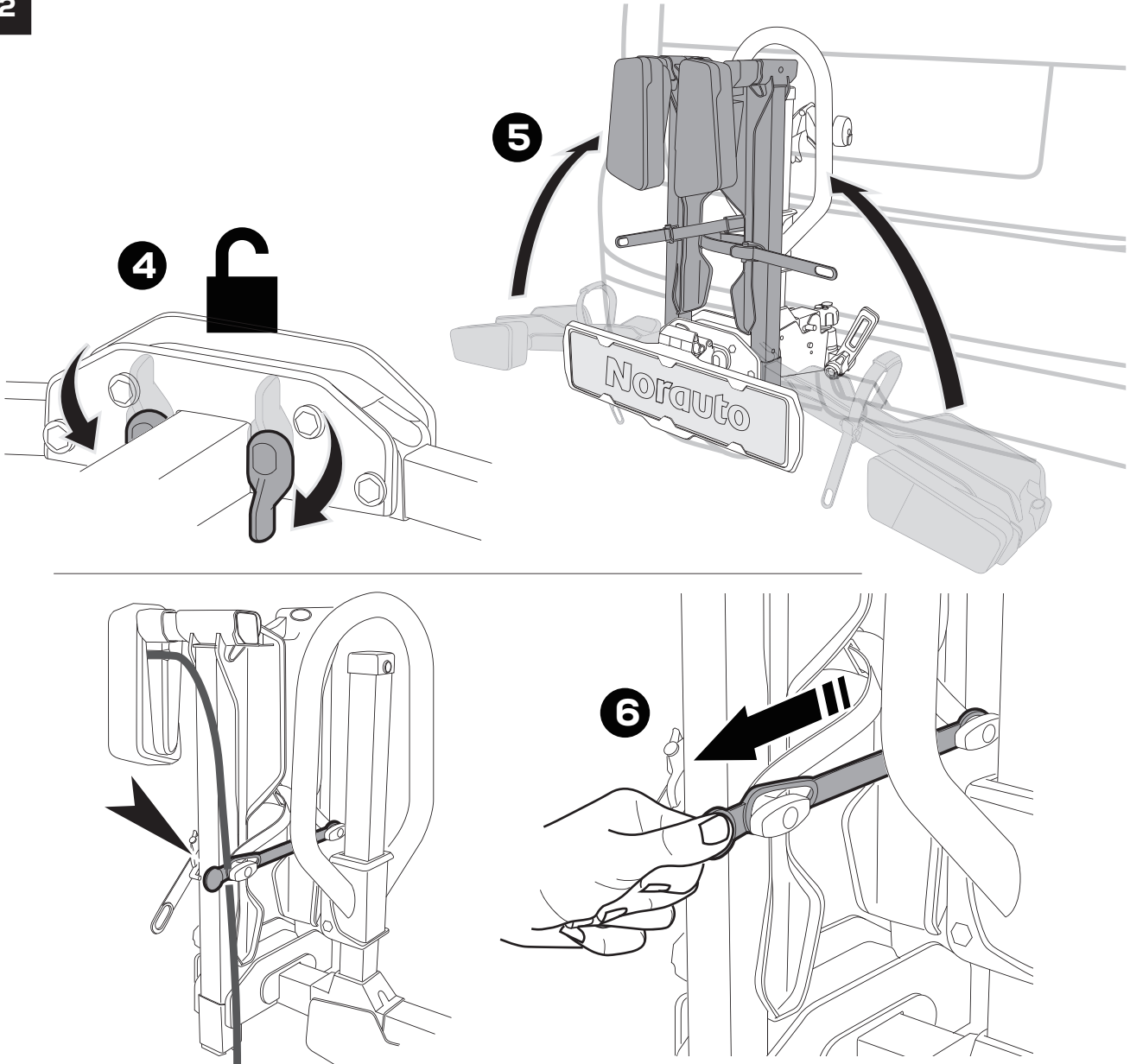

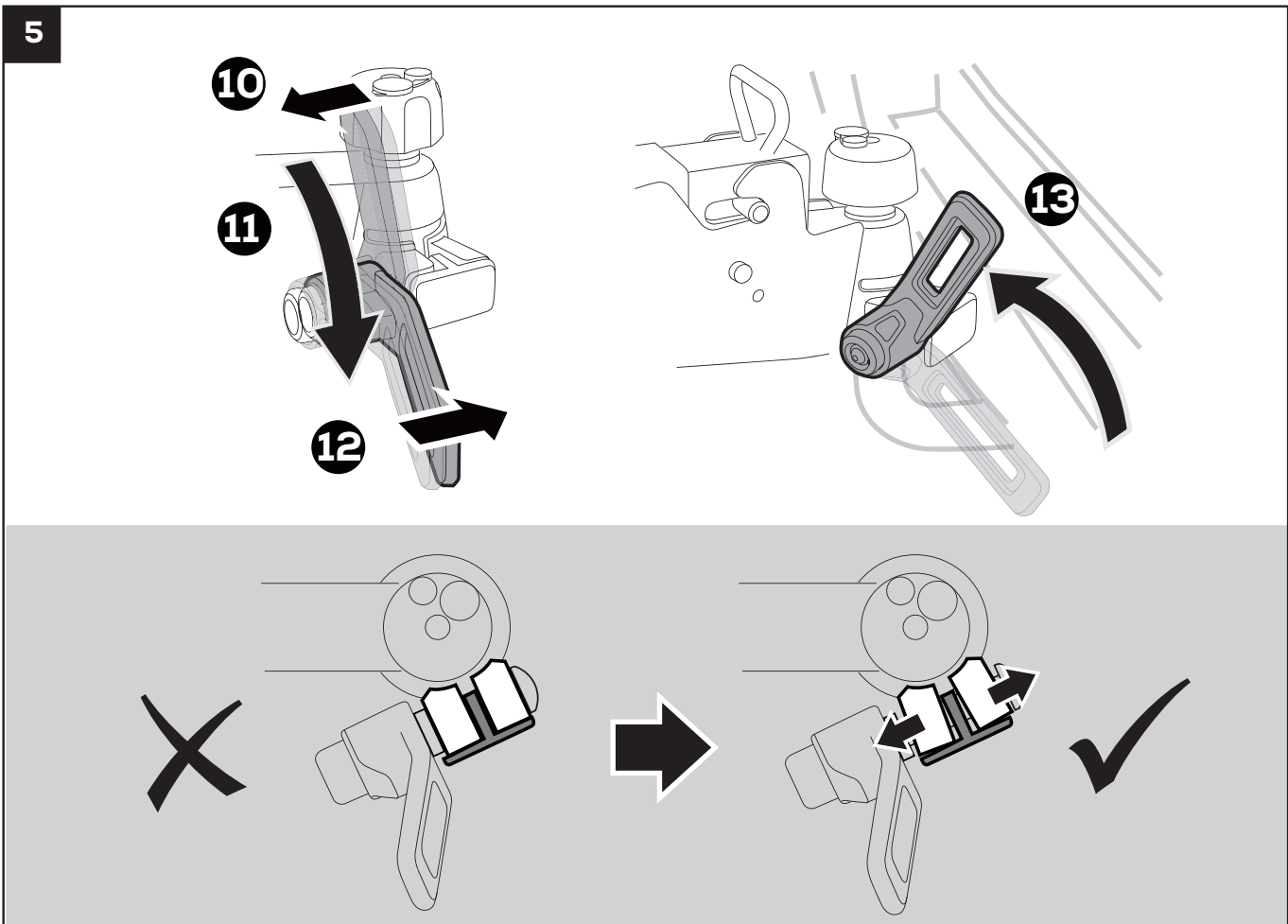
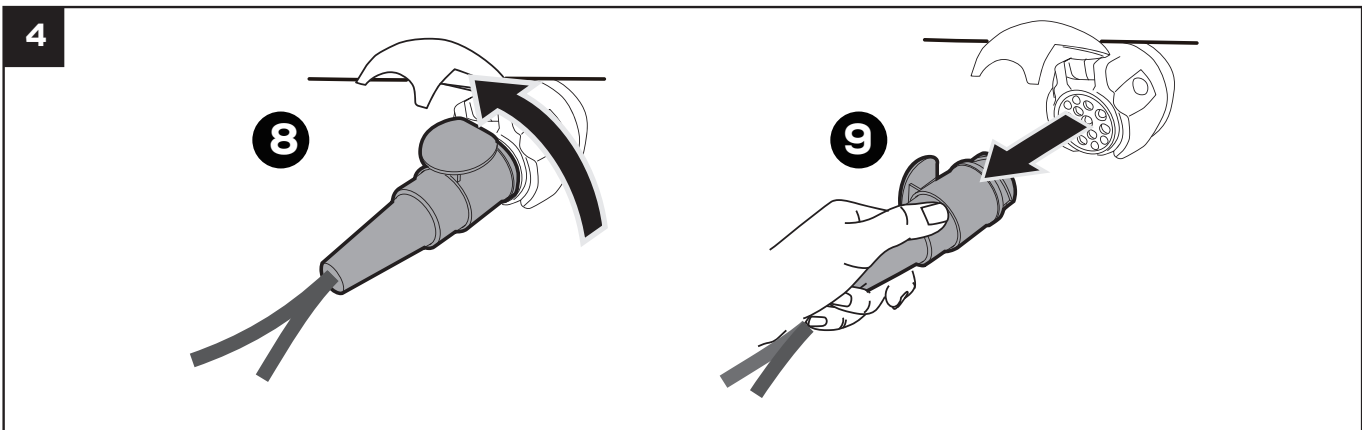
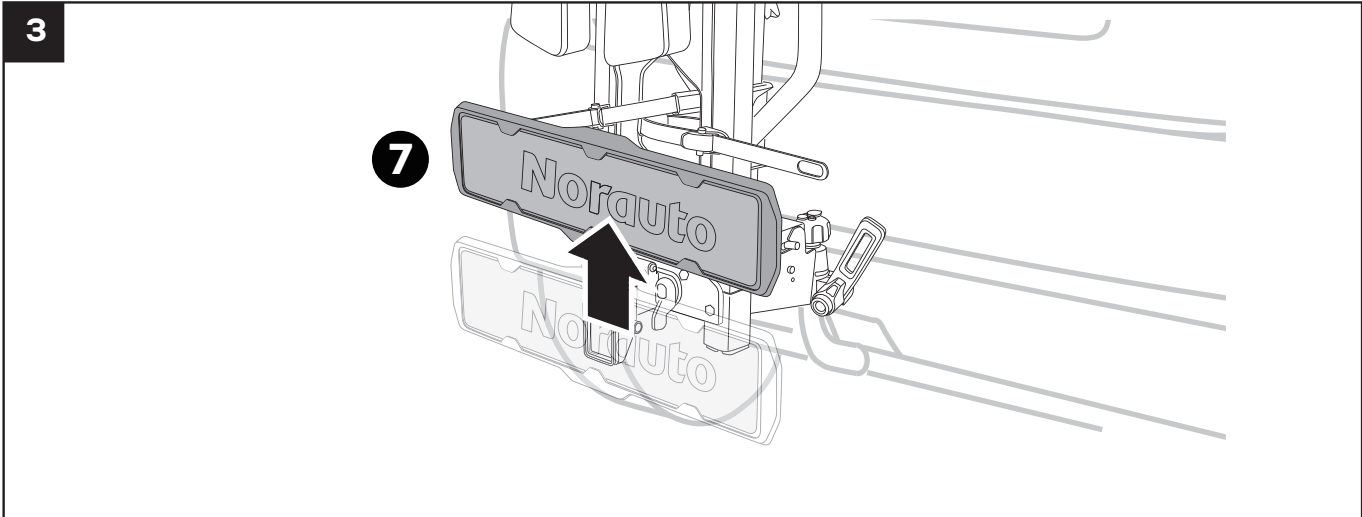

6

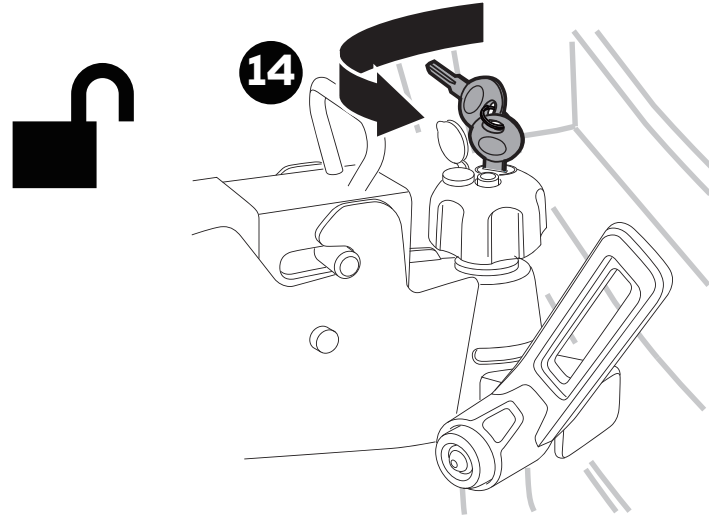

7

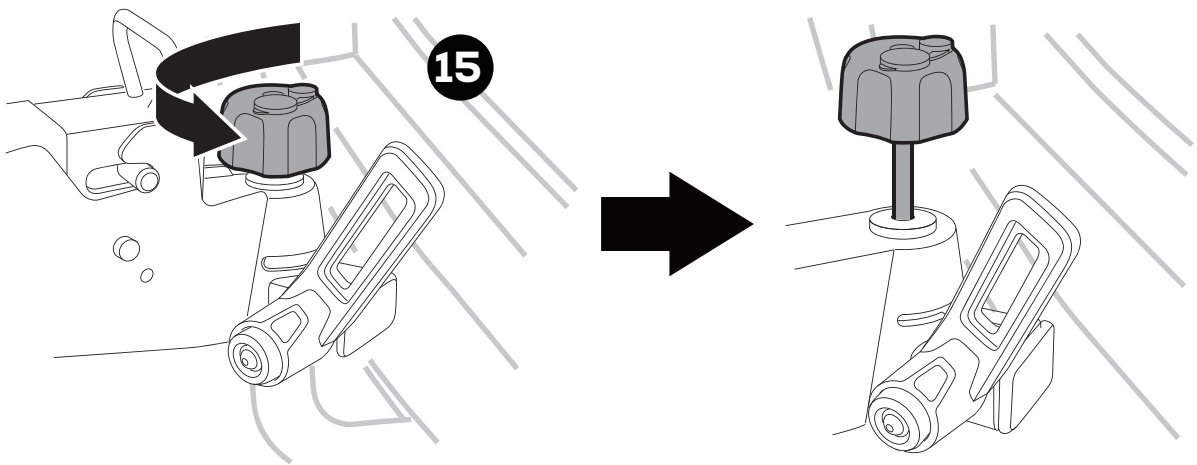

8

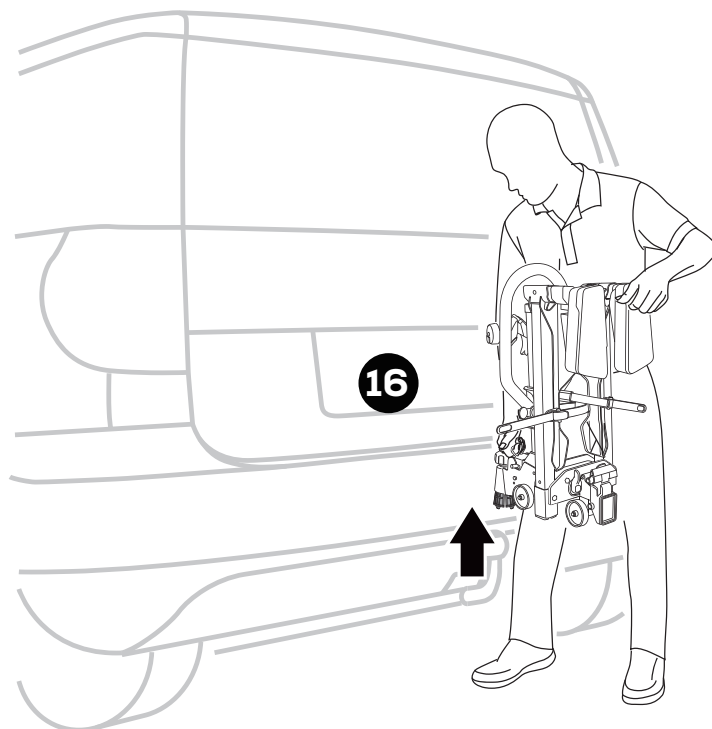

9

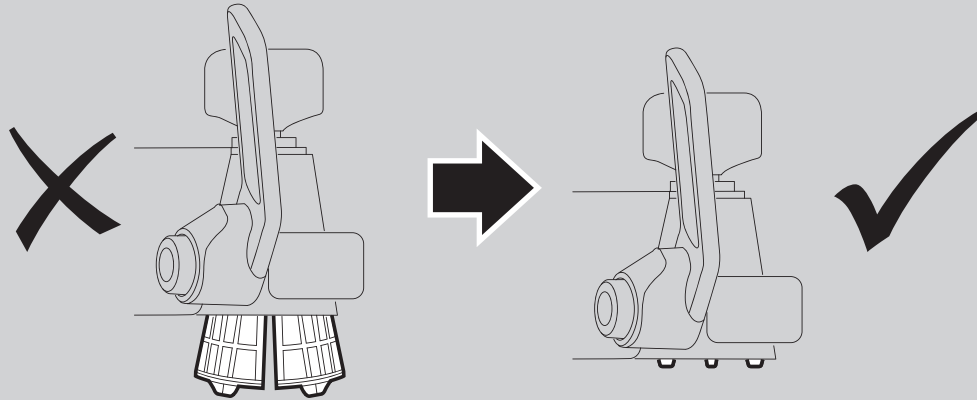
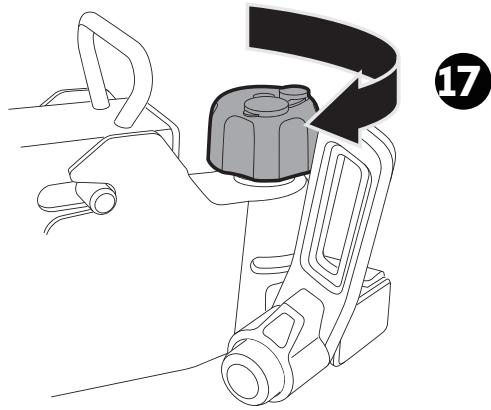

10

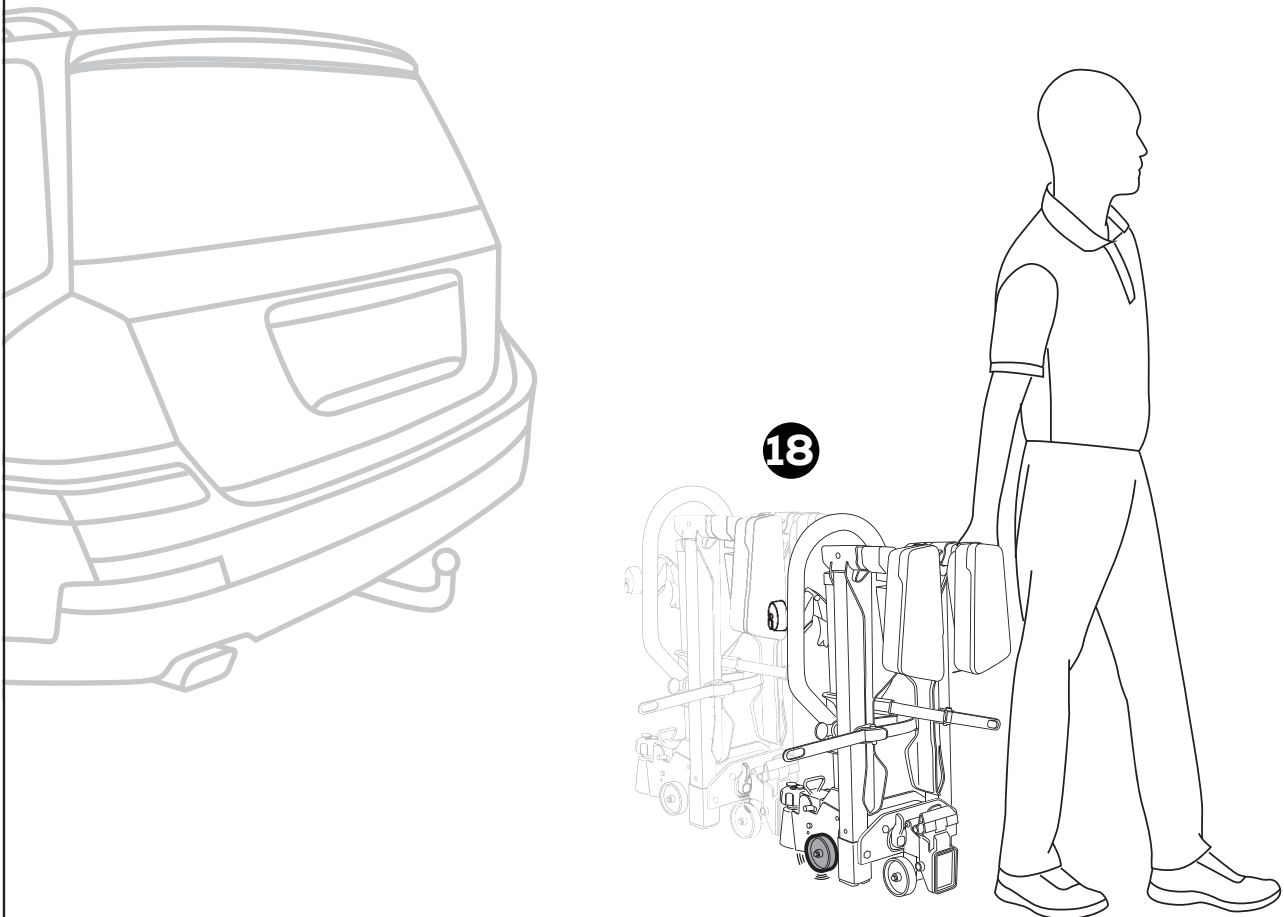

NORAUTO
511/589 rue des Seringats 59262 Sainghin-en-Mélantois France
www.norauto.com
www.atu.eu
Made in Taiwan / Fabricado en/na Taiwan / Fabriqué à Taiwan

 **Mobivia**

