

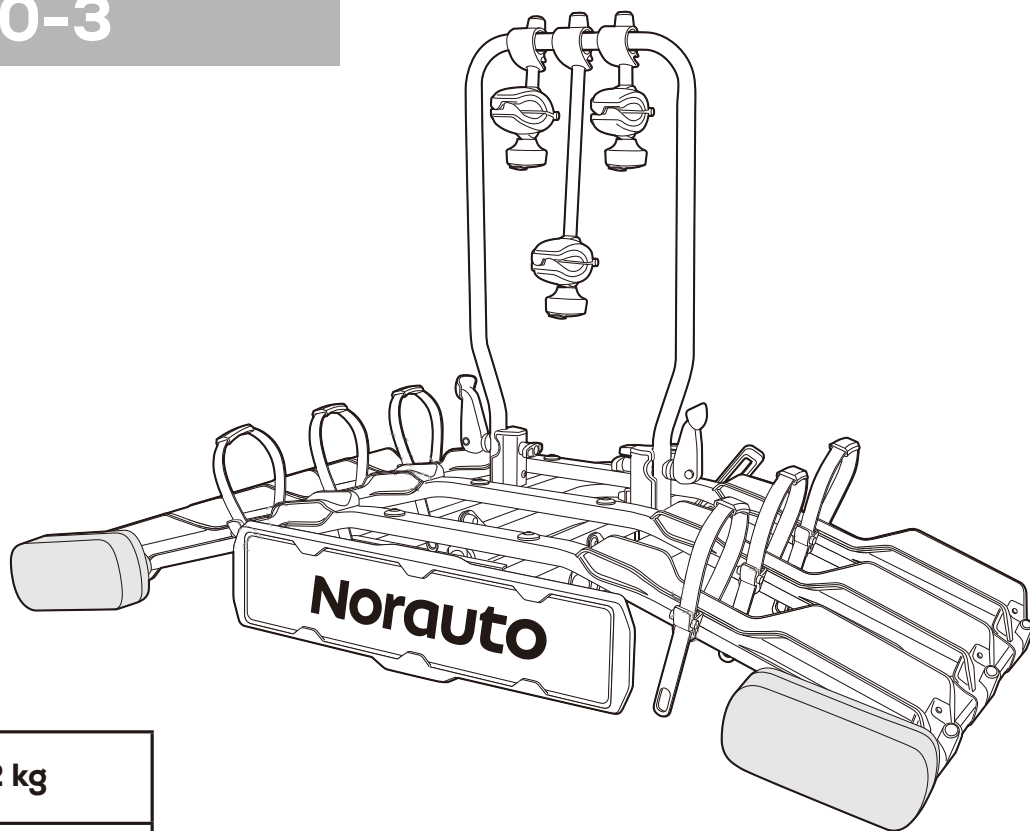



# Norauto

PORTE-VÉLOS D'ATTELAGE  
FIETSDRAGER VOOR OP  
TREKHAAK  
FAHRRADHECKTRÄGER  
ANHÄNGERKUPPLUNG  
PROTABICICLETAS DE  
ENGANCHE  
TOWABLE BICYCLE RACK  
PORTABICI DA GANCIO TRAINO  
PORTA-BICICLETAS DE ENGATE

## E-FIT 100-3

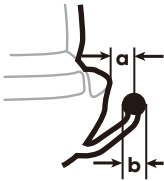

	<b>19.2 kg</b>
	<b>a: &gt;65mm</b> <b>b: Ø50mm</b>
	<b>MAX 60kg</b>

Lisez impérativement le manuel d'utilisation avant toute utilisation du produit.  
De handleiding verplicht lezen voor elke ingebruikname  
Vor der Verwendung des Produkts ist diese Bedienungsanleitung aufmerksam durchzulesen.  
Es esencial leer el manual antes de usar el producto.  
It is essential to read the manual before use.  
È essenziale leggere il manuale prima dell'uso.  
Leia o manual do utilizador antes de utilizar o produto.

ART: 2396726 - NO1025

**FR** - Notice d'utilisation / **NL** - Gebruiksaanwijzing  
**DE** - Bedienungsanleitung / **ES** - Instrucciones  
**EN** - User manual / **IT** - Istruzioni per l'uso  
**PT** - Instruções de utilização





PIÈCES / WISSELSTUKKEN / TEILE / PIEZAS / PARTS/  
PEZZI / PEÇAS

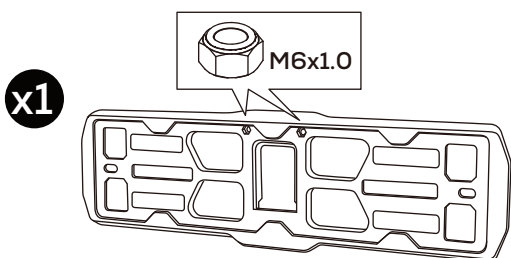
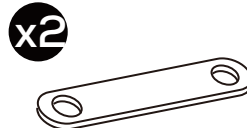
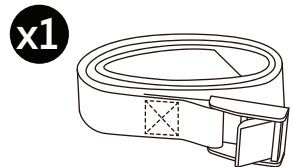
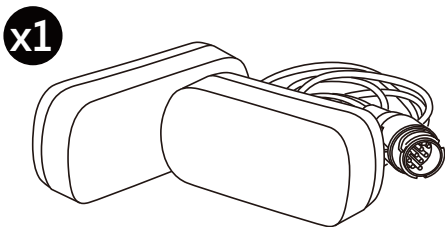
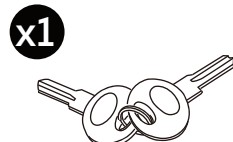
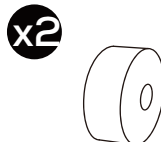
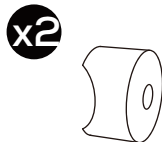
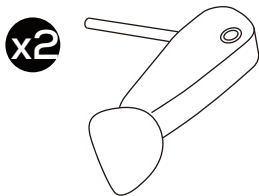
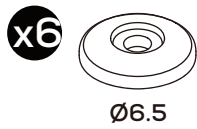
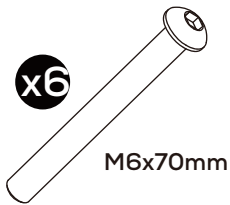
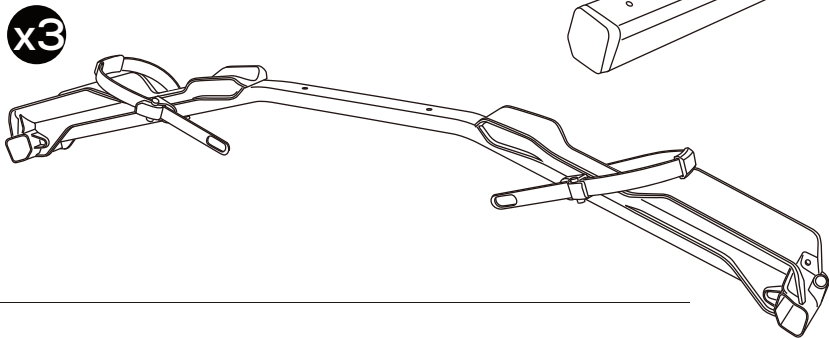
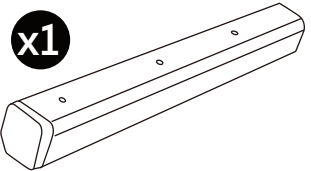
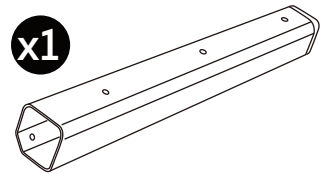
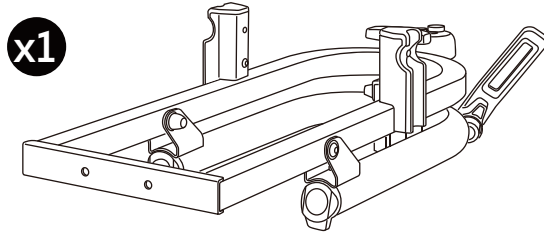
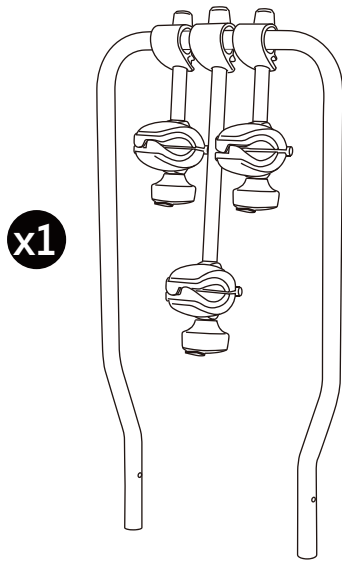

Tool

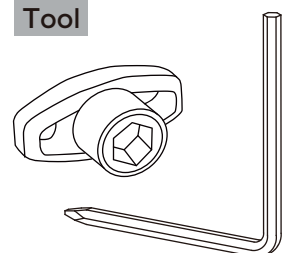



ASSEMBLAGE DU PORTE-VÉLOS / DE PRODUCTIE VAN DE FIETSENDRAGER  
MONTAGE DES FAHRRADTRÄGERS / ENSAMBLAJE DEL PORTABICIS  
ASSEMBLY OF THE BICYCLE RACK / ASSEMBLAGGIO DEL PORTABICI  
MONTAGEM DO PORTA-BICILETAS

1

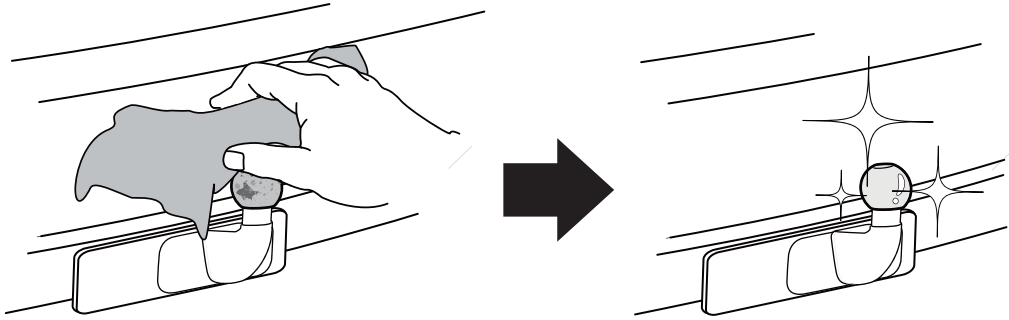

2

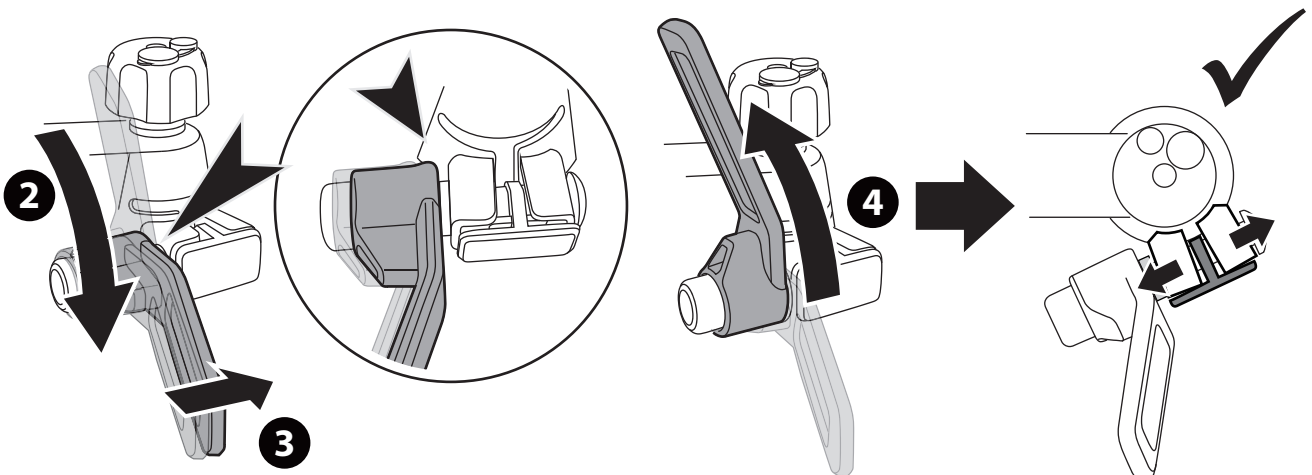
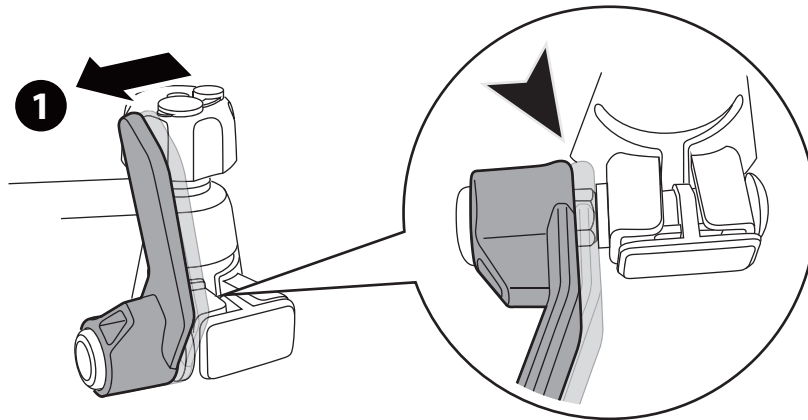
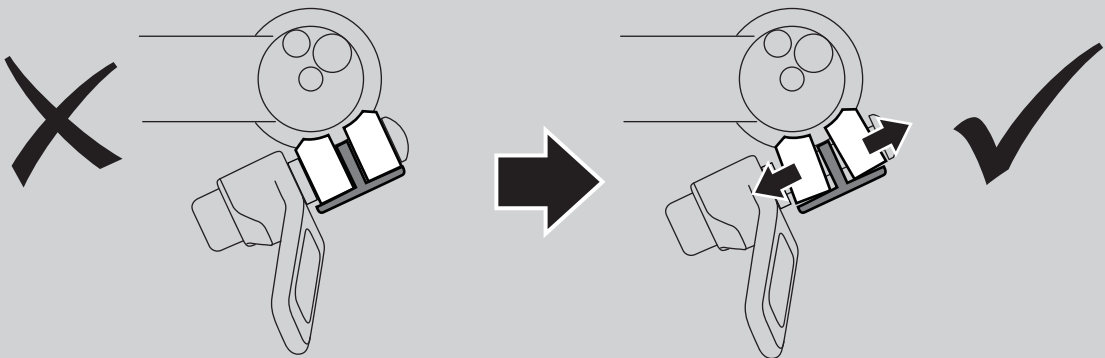

3

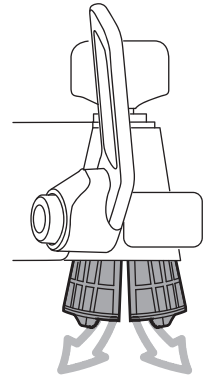
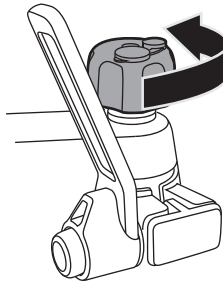
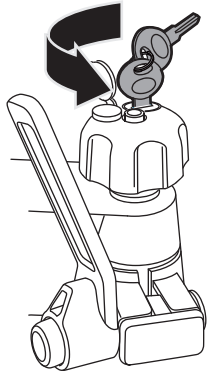
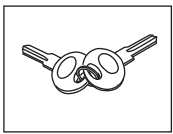

4

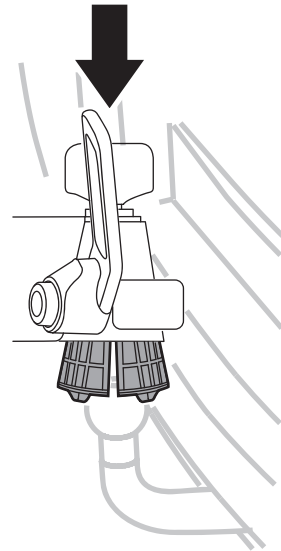
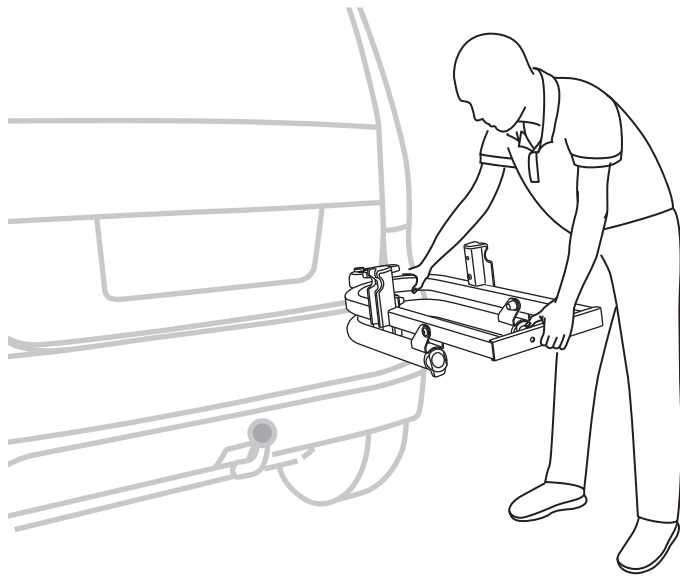

5

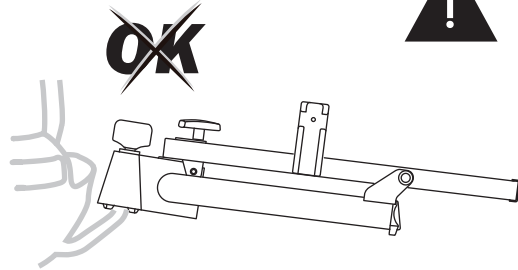
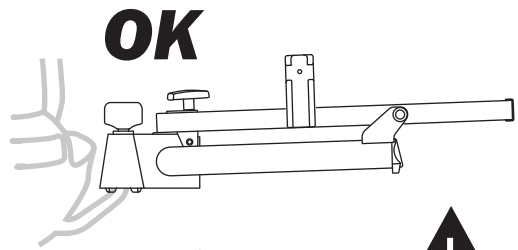

6

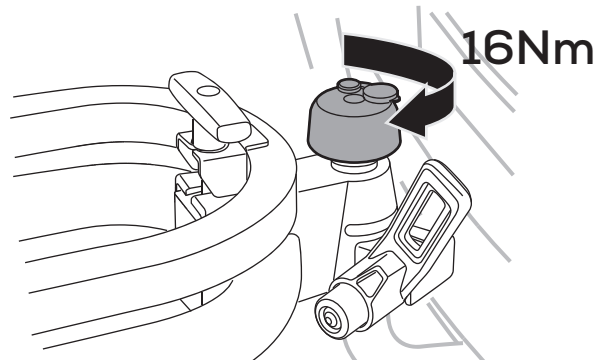
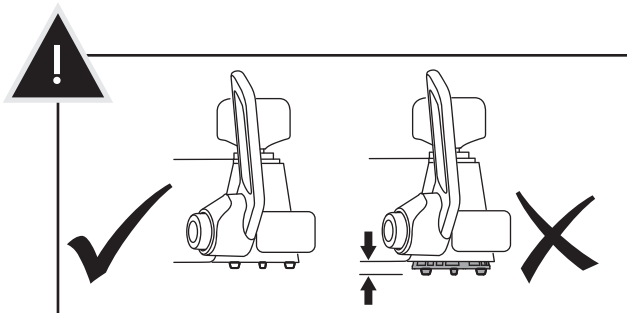

7

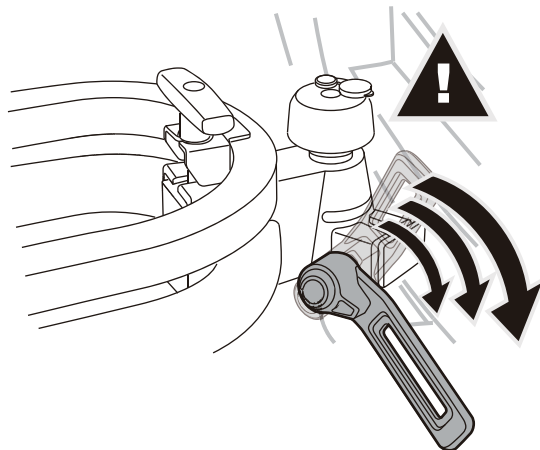

8

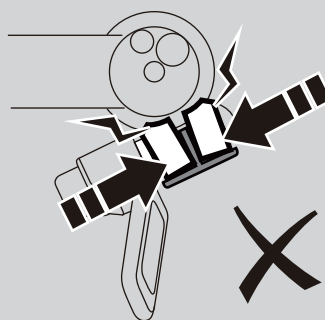
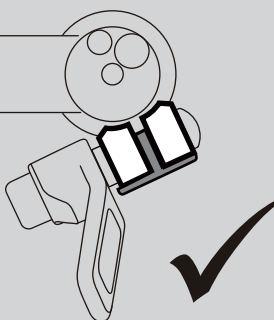
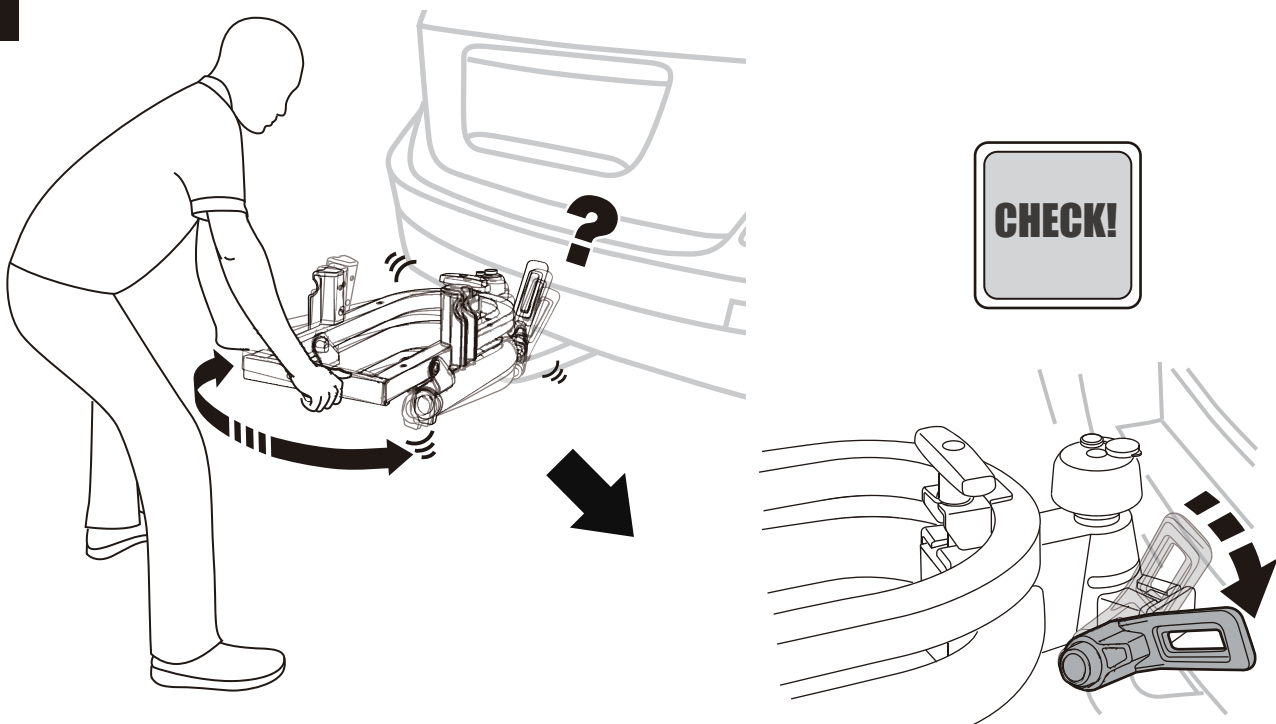

9

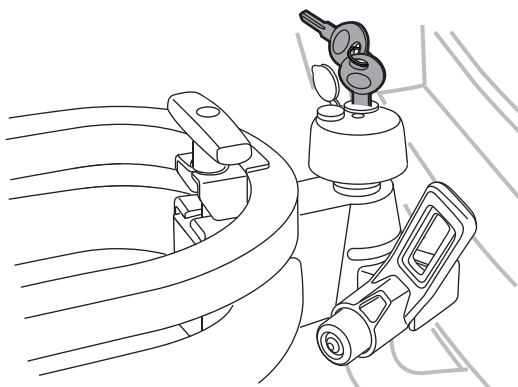
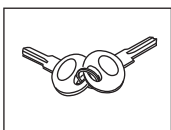

ASSEMBLAGE DU PORTE-VÉLOS / DE PRODUCTIE VAN DE FIETSENDRAGER  
 MONTAGE DES FAHRRADTRÄGERS / ENSAMBLAJE DEL PORTABICIS  
 ASSEMBLY OF THE BICYCLE RACK / ASSEMBLAGGIO DEL PORTABICICI  
 MONTAGEM DO PORTA-BICILETAS





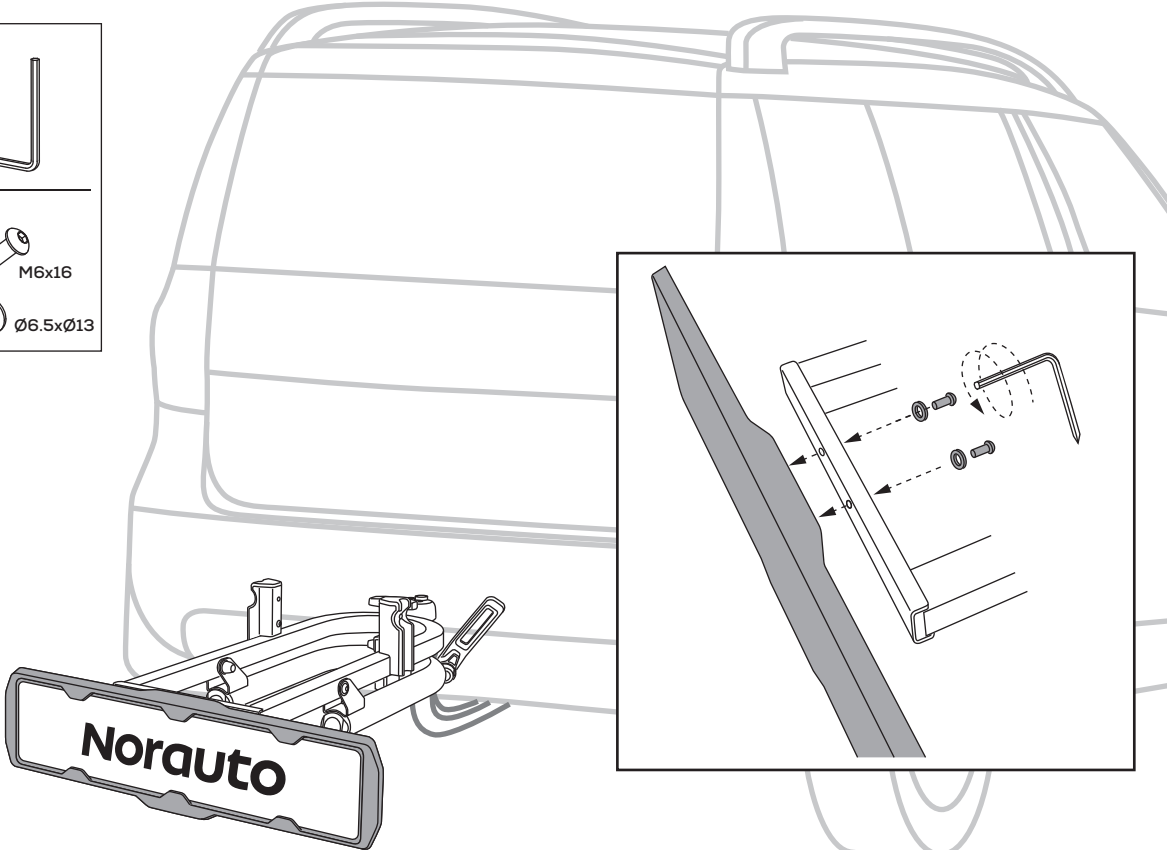
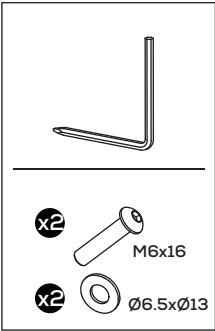
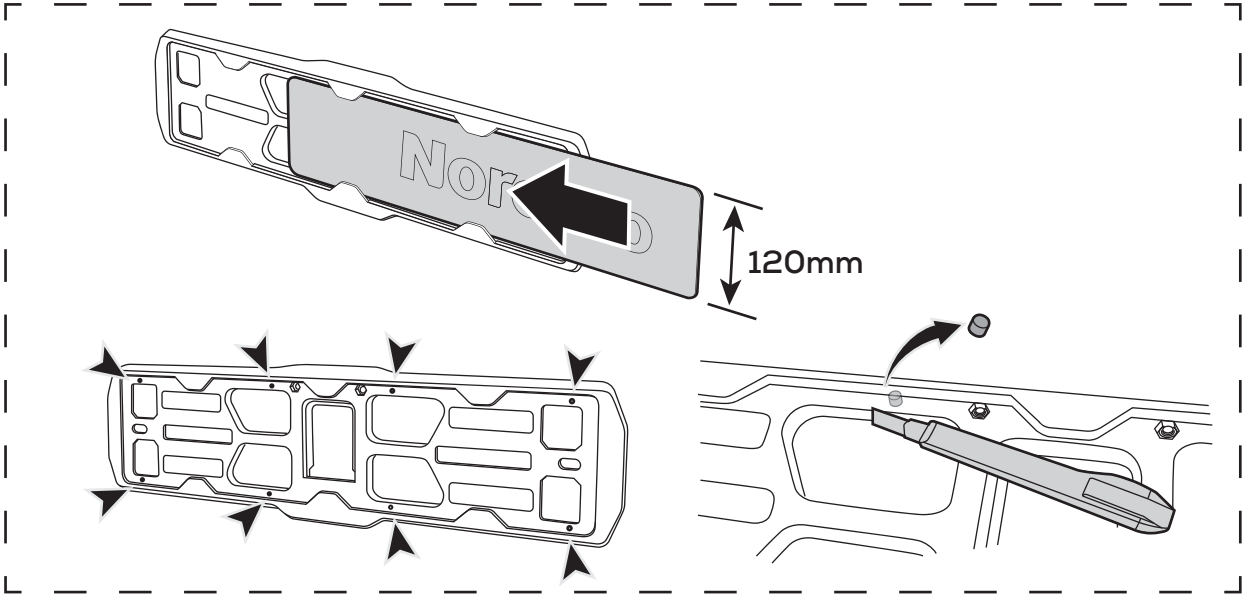
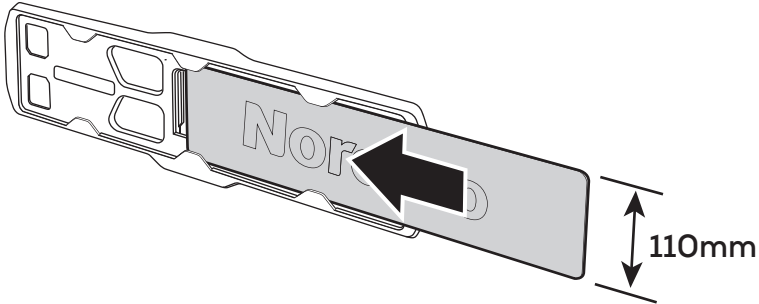

1

**Norauto**

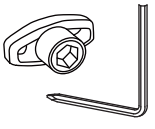
\* This plate is not included.





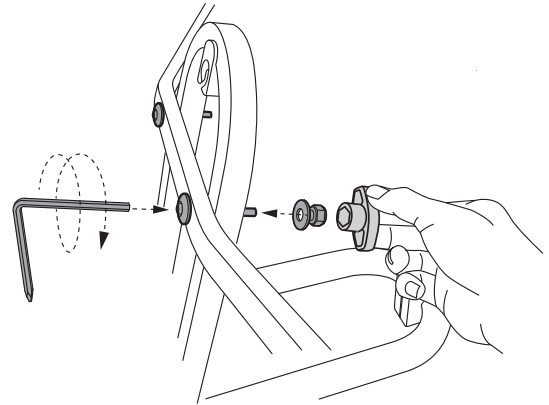
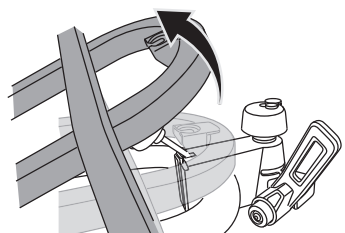
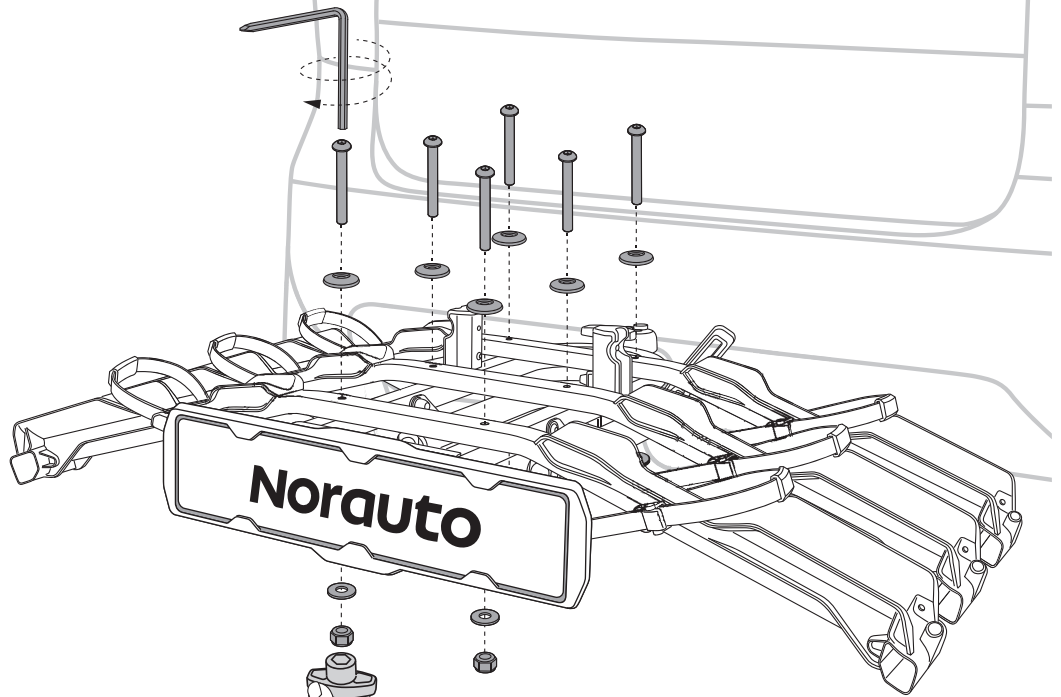

2

- 
- x3** 
- x6**  M6x70
- x6** 
- x6**  Ø6.5xØ13
- x6**  M6x1.0

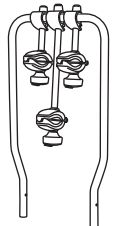

3

- x1** 
- x2** 
- x2** 
- x2**  **x2** 

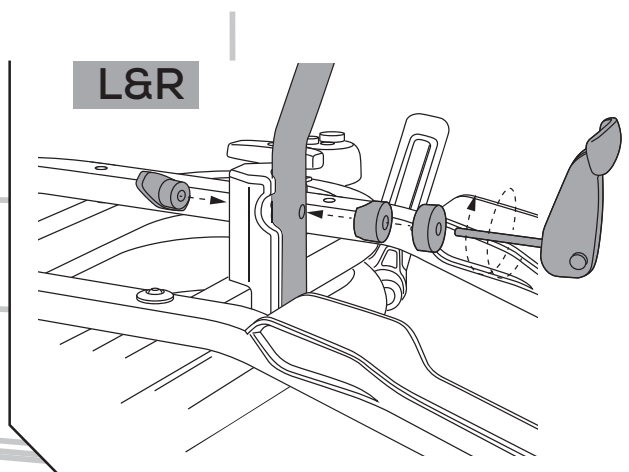
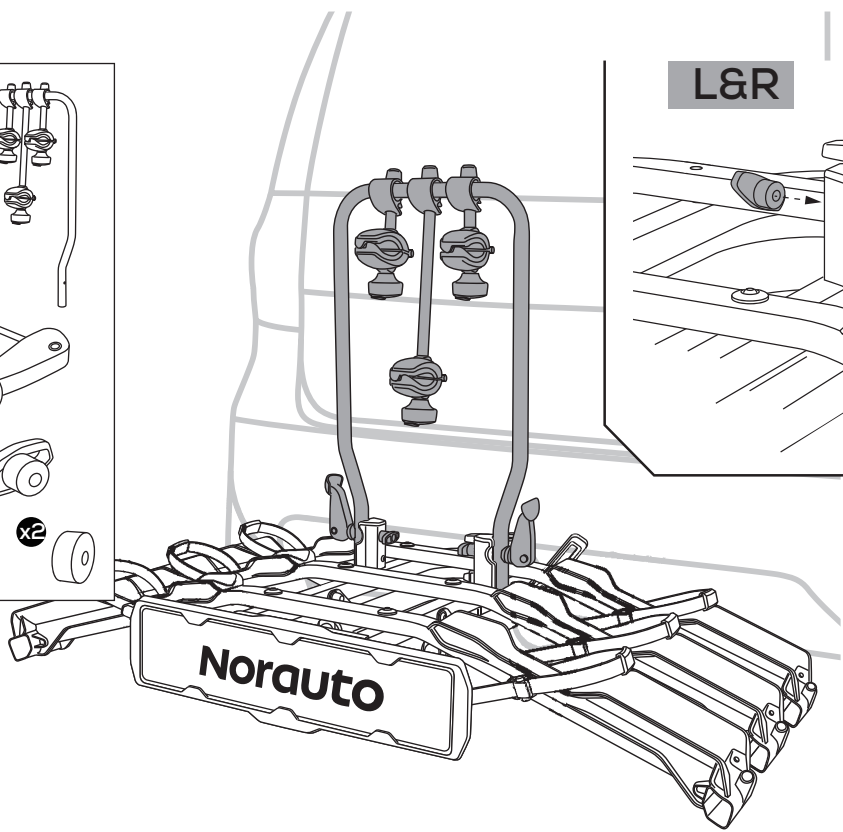

4

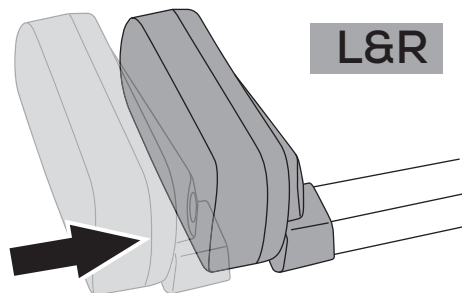
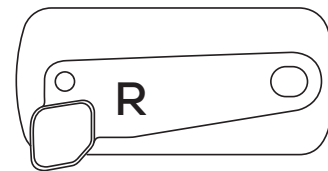
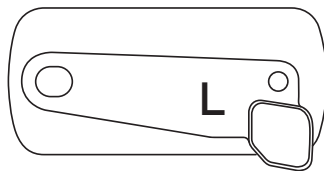
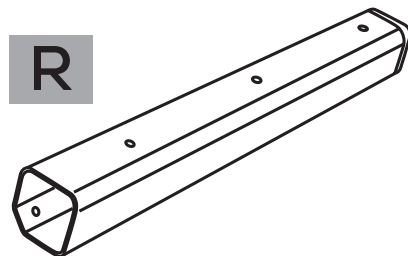
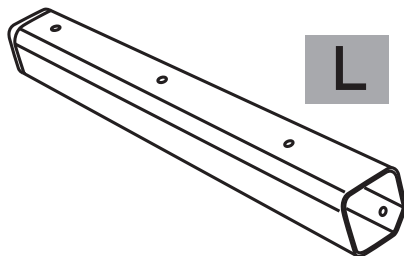
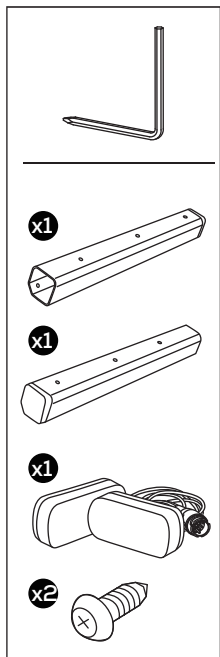

L&R

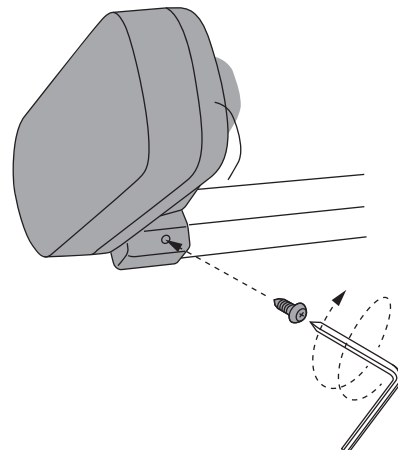

5

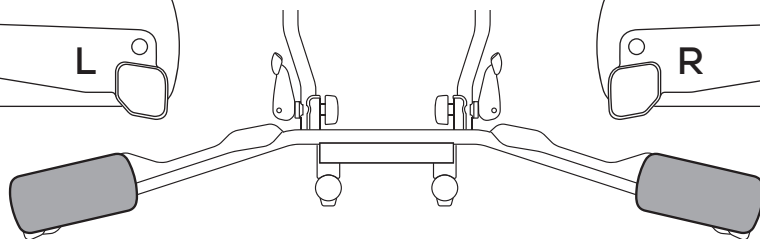
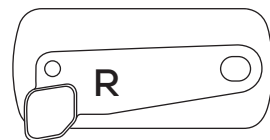
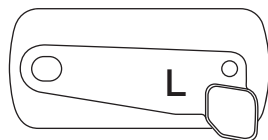
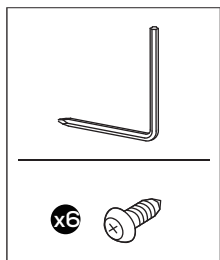

L&R

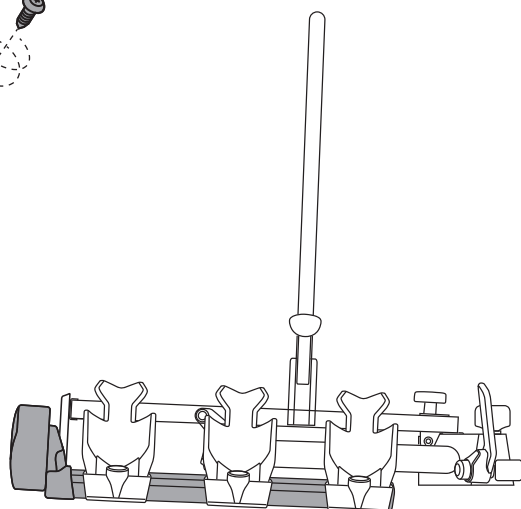
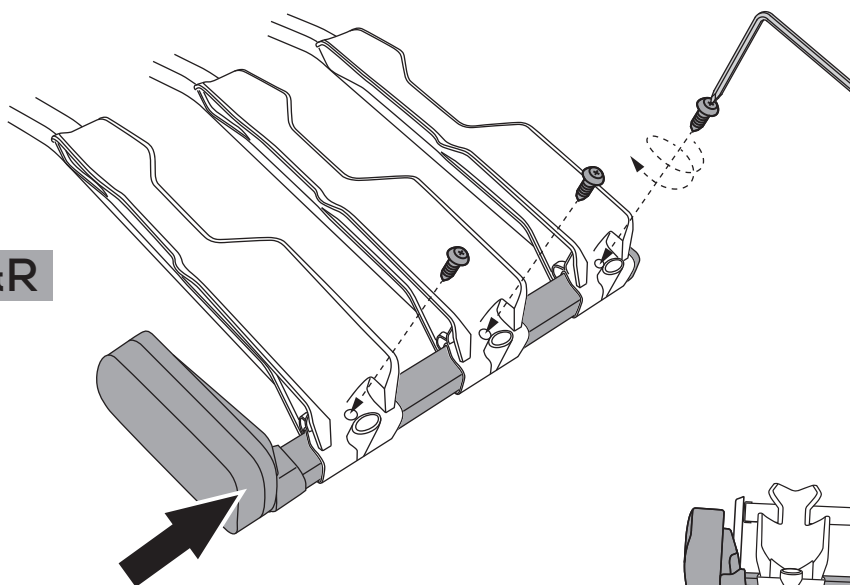



6

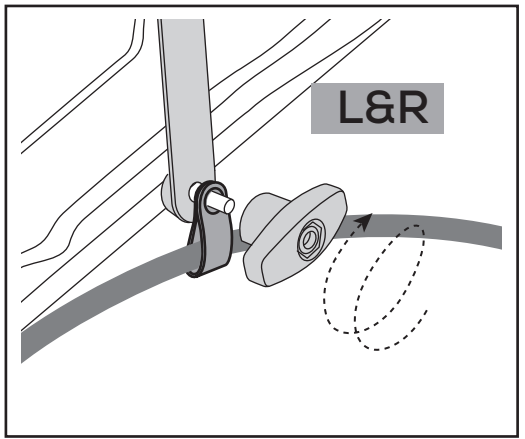
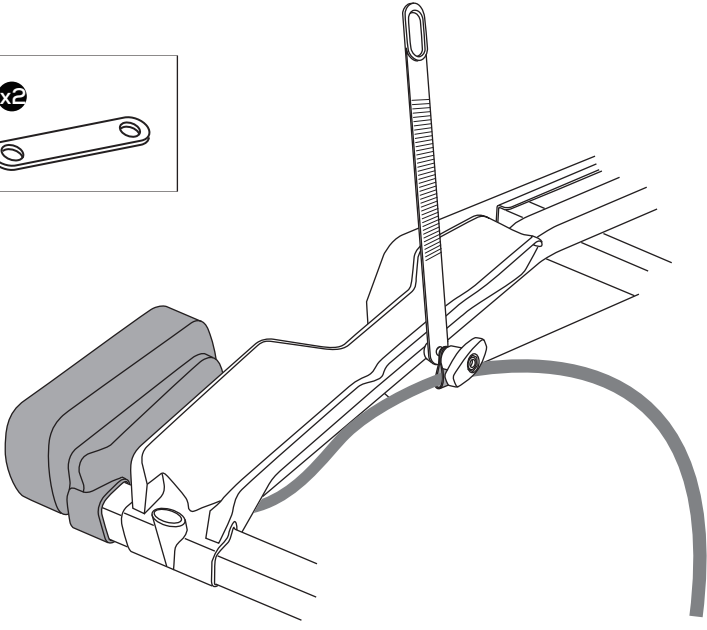
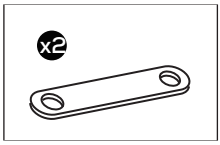

7

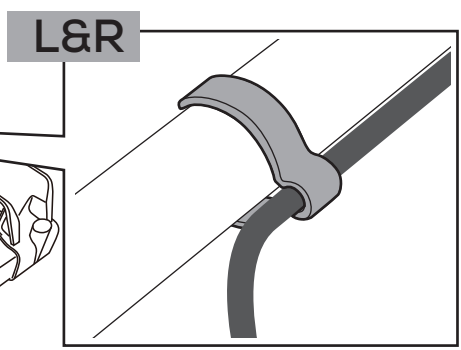
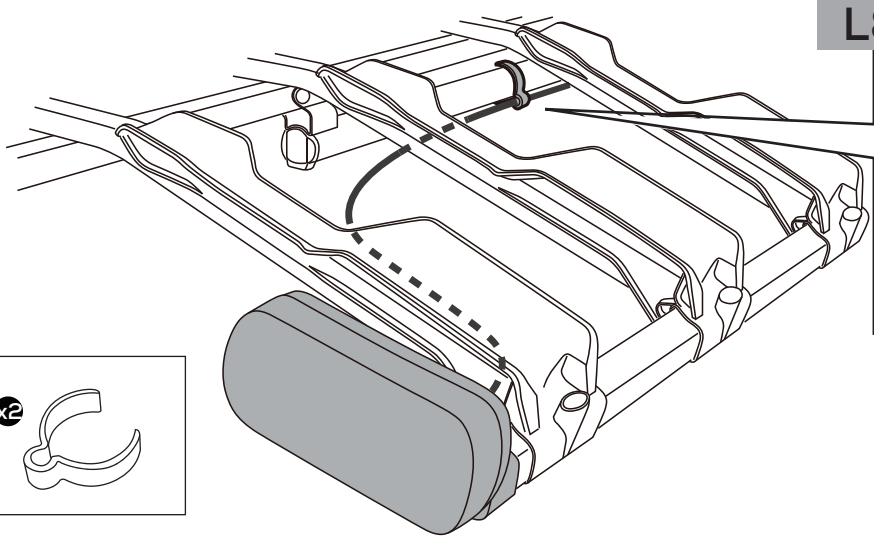
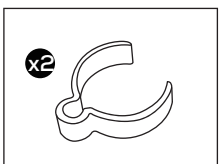

8

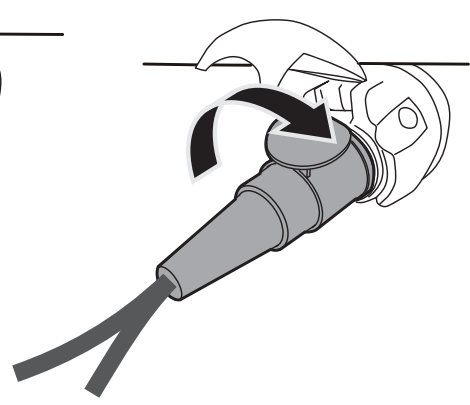
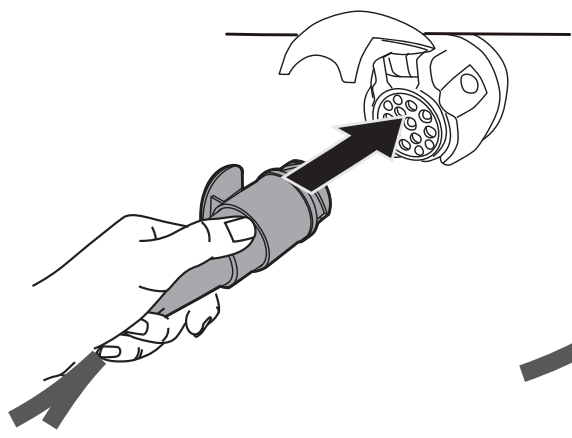
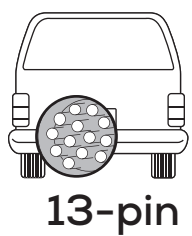

MONTAGE DES VÉLOS / MONTAGE VAN DE FIETSEN / MONTAGE DER FAHRRÄDER  
MONTAJE DE LAS BICICLETAS / BICYCLES MOUNTING  
MONTAGGIO DELLE BICI / MONTAGEM DAS BICICLETAS

**MAX  
60kg**



**MAX 60 kg**

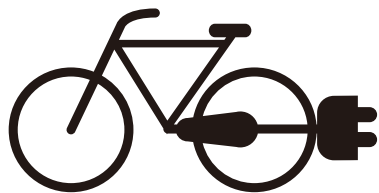
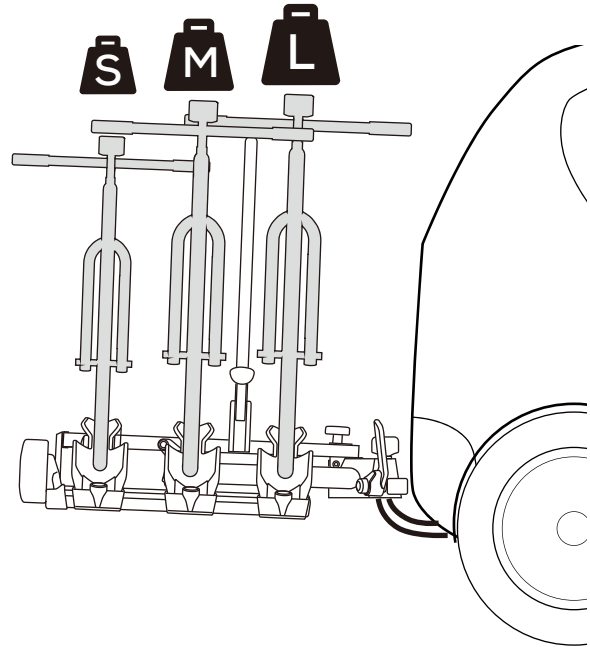

**2 x 30kg = MAX  
60 kg**

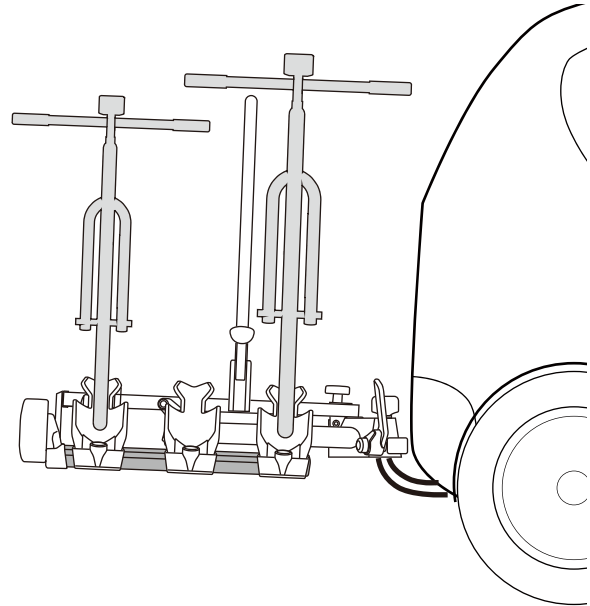

**E-Bike**

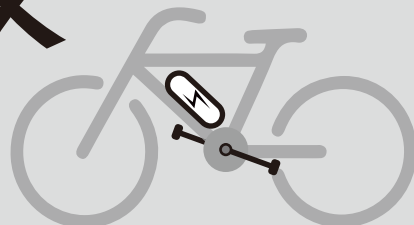

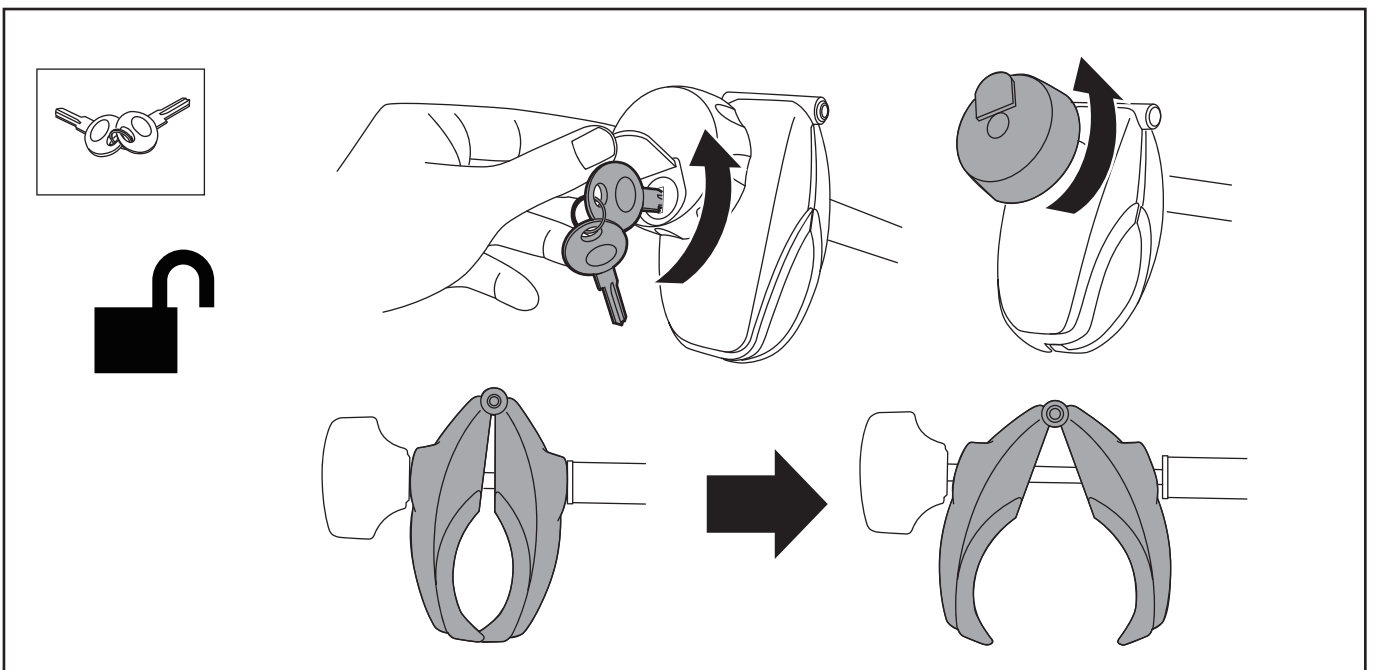
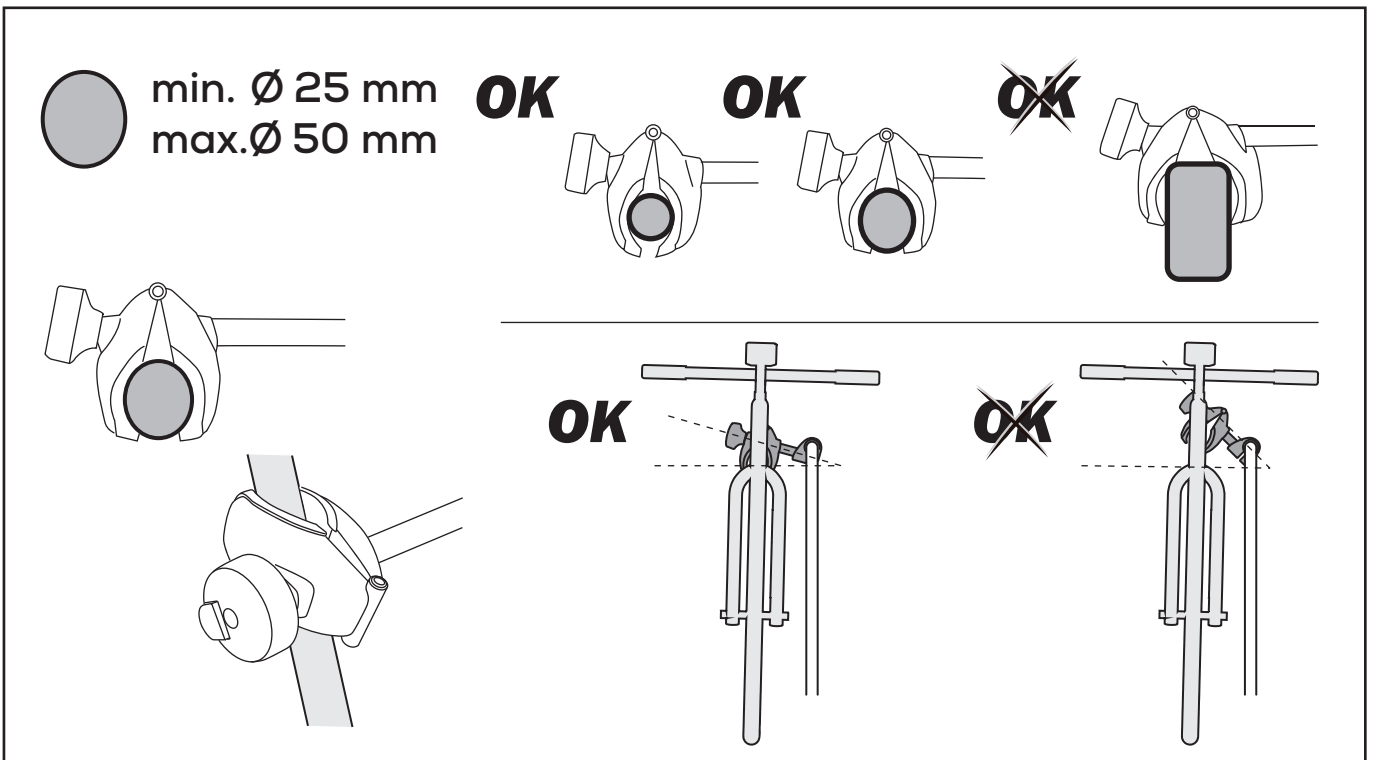
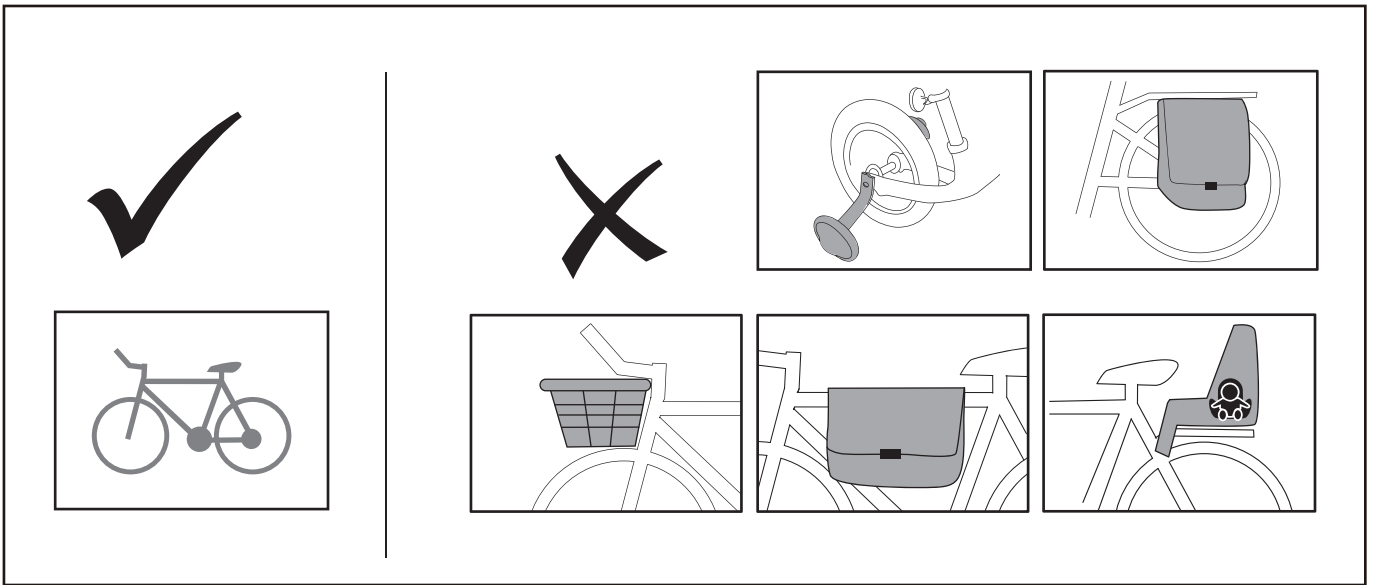

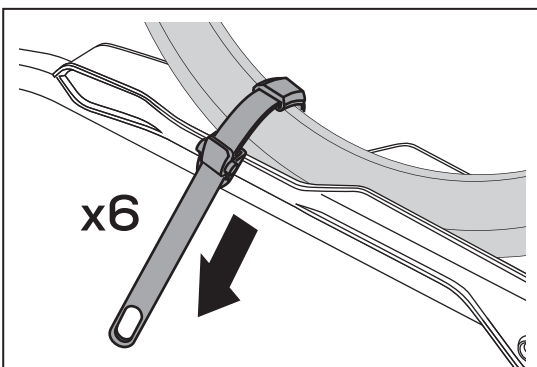
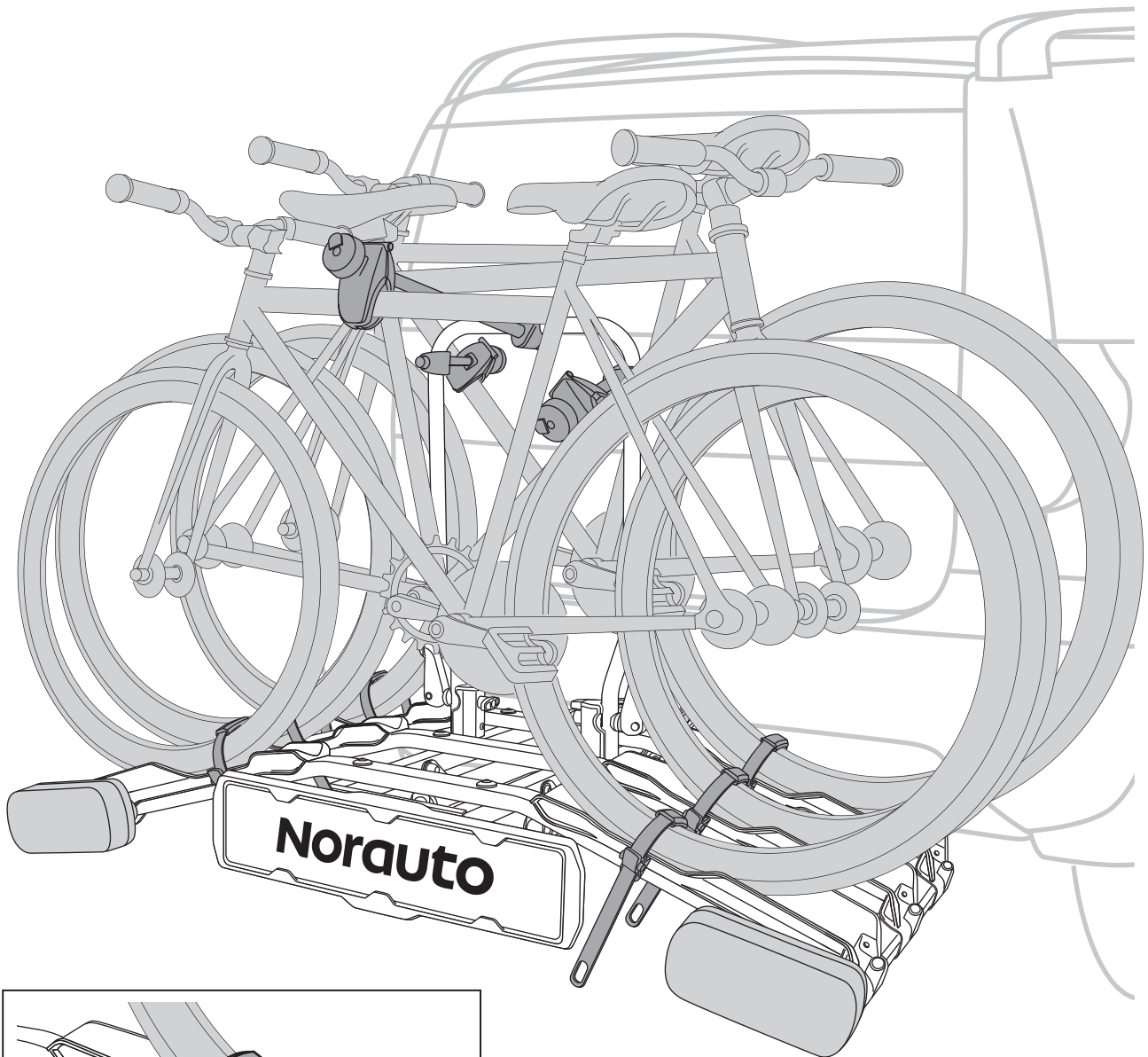
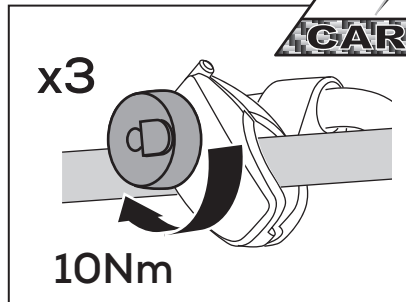
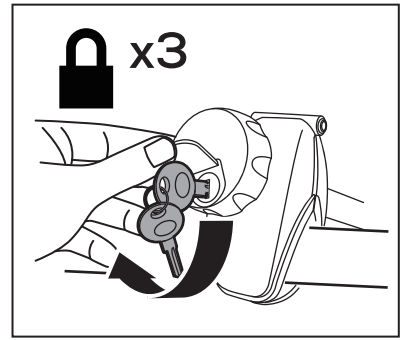
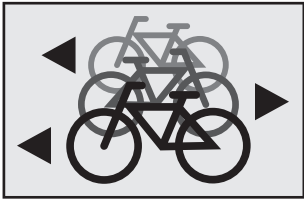

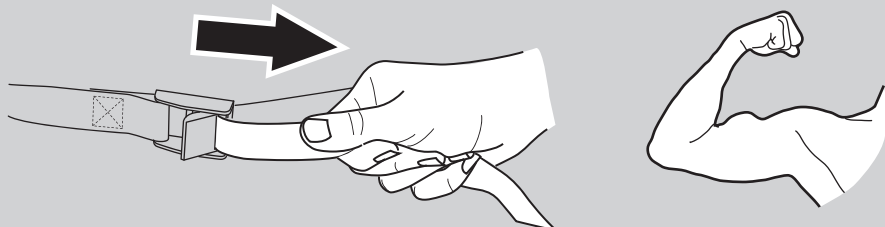
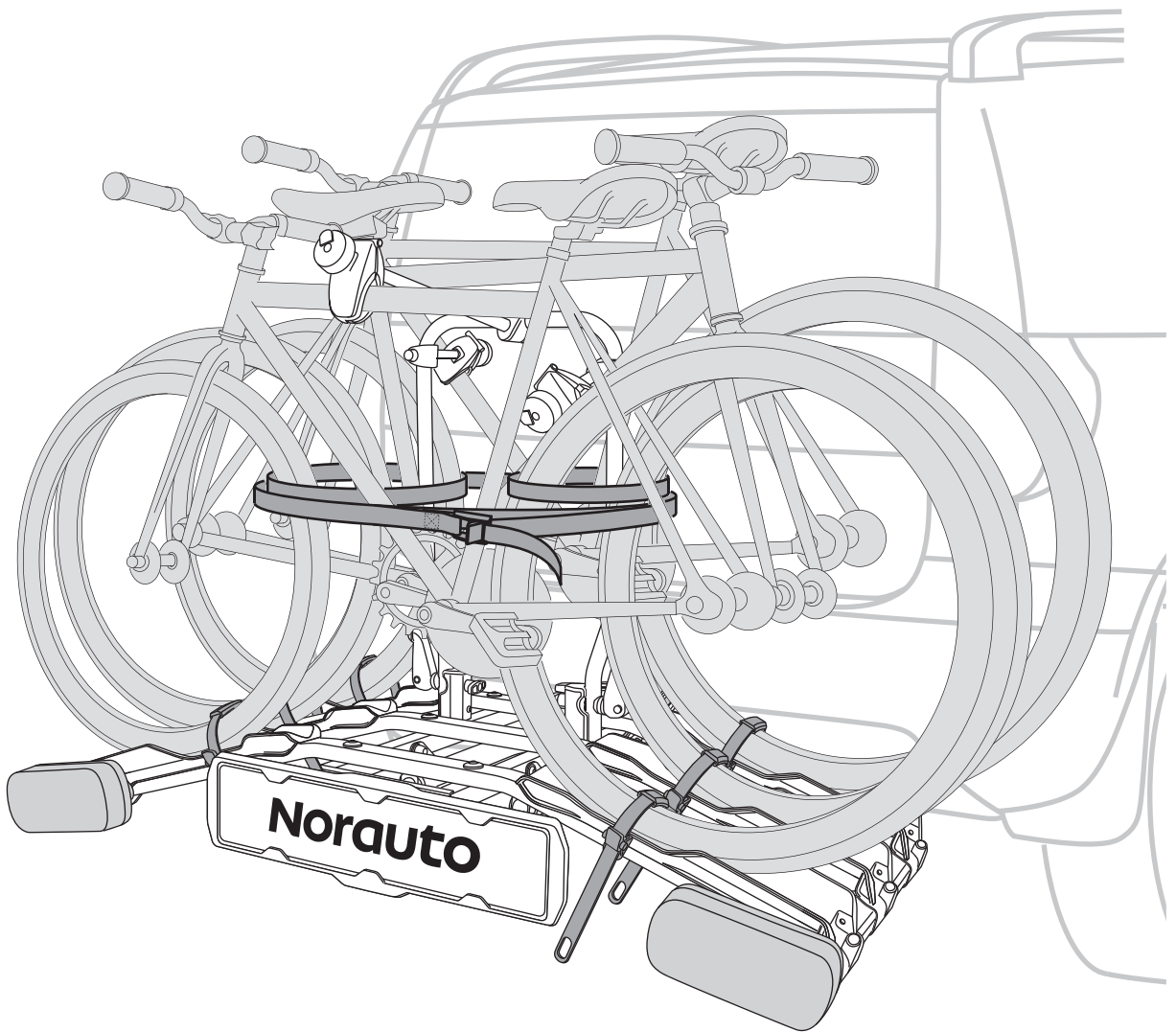
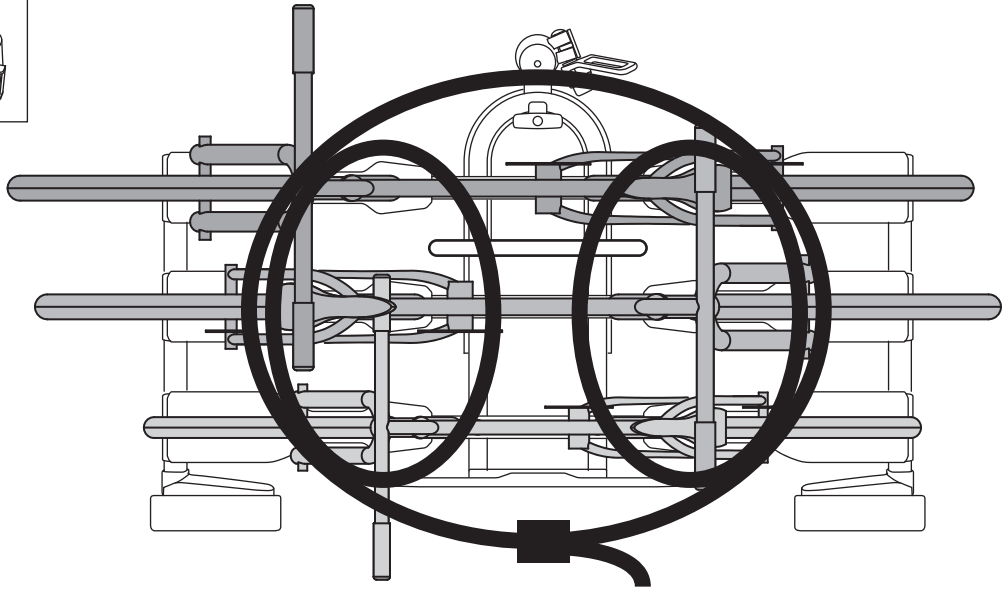
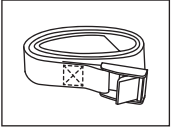

**BASCULEMENT DU PORTE-VÉLOS POUR UN ACCES AU COFFRE**  
**KANTELEN VAN DE FIETSENDRAGER OM TOEGANG TE HEBBEN TOT DE KOFFER**  
**ABKLAPPEN DES FAHRRADTRÄGERS ZUM ÖFFNEN DES KOFFERRAUMS**  
**EL PORTABICIS BASCULA PARA PODER ACCEDER AL MALETERO**  
**TILTING OF THE BICYCLE RACK FOR AN EASY ACCESS TO THE TRUNK**  
**PORTABICI BASCULANTE PER ACCEDERE AL BAULE**  
**BASCULAR O PORTA BICICLETAS PARA ACEDER Á MALA**

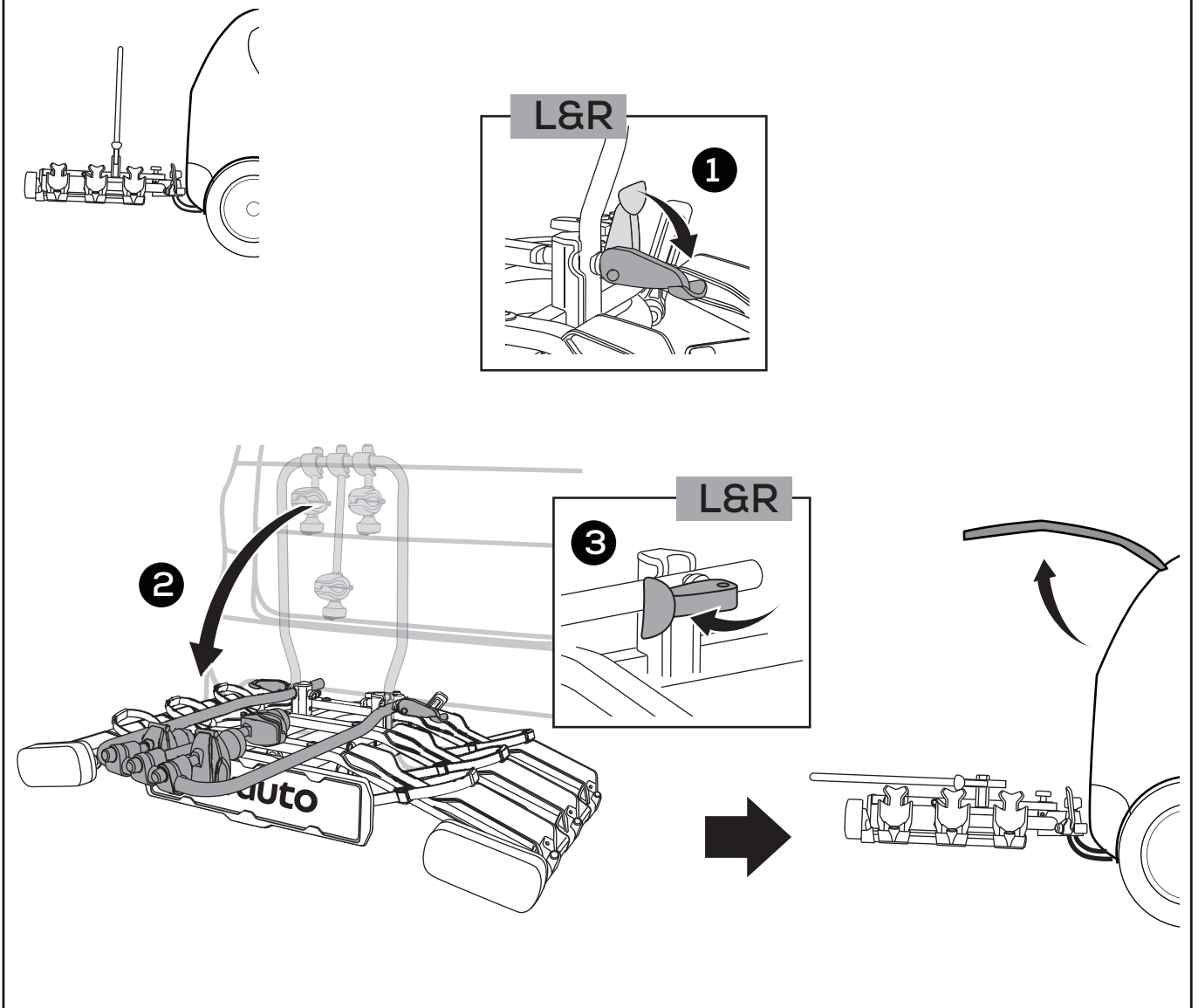
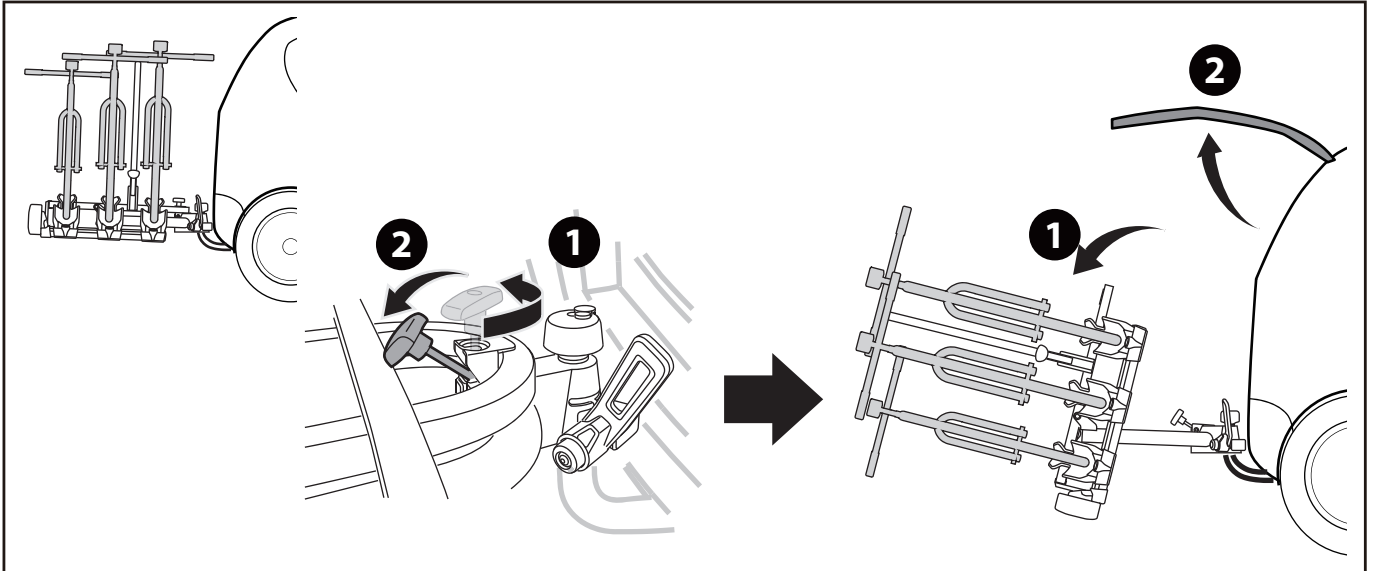

DEMONTAGE / DESMONTAJE / ABMONTIEREN / DISASSEMBLY  
SMONTAGGIO / DESMONTAGEM

1

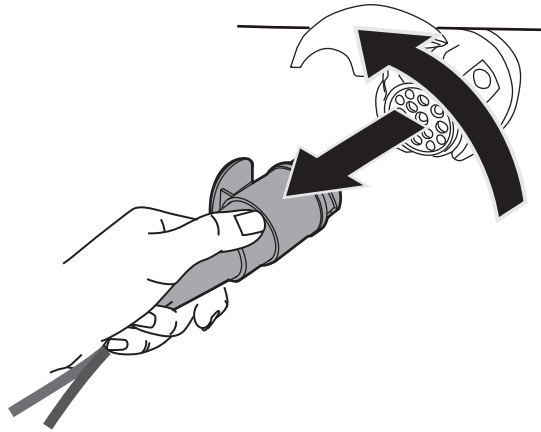

2

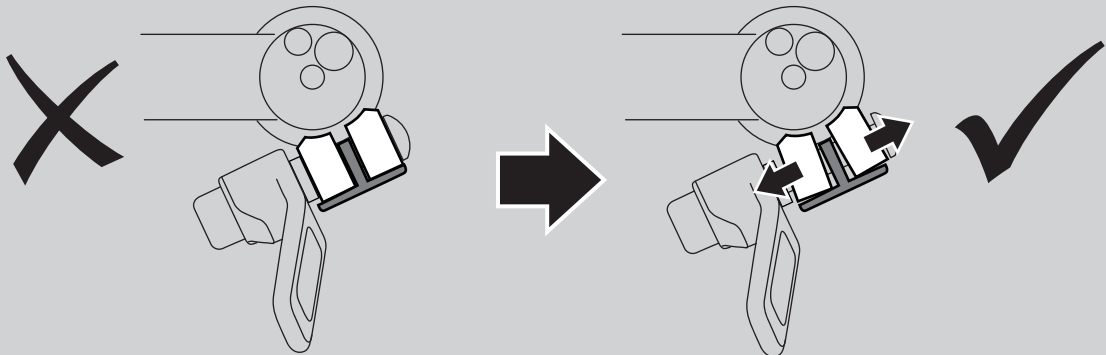
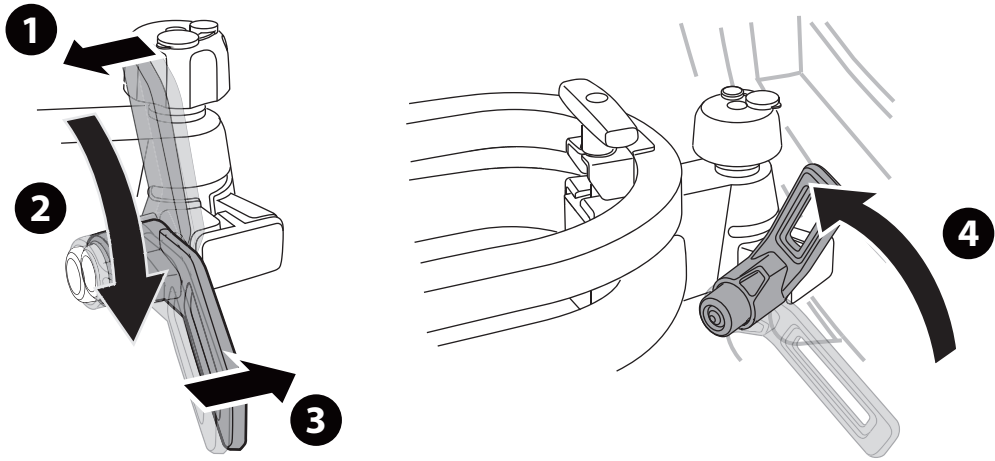

3

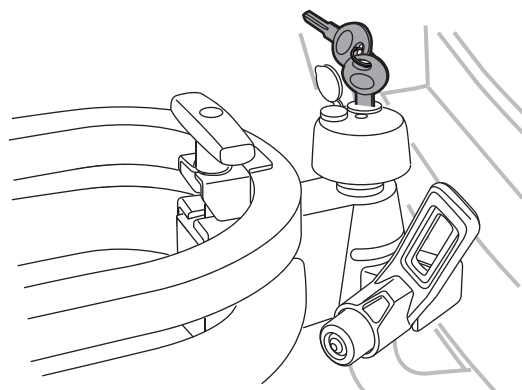
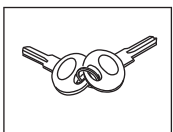

4

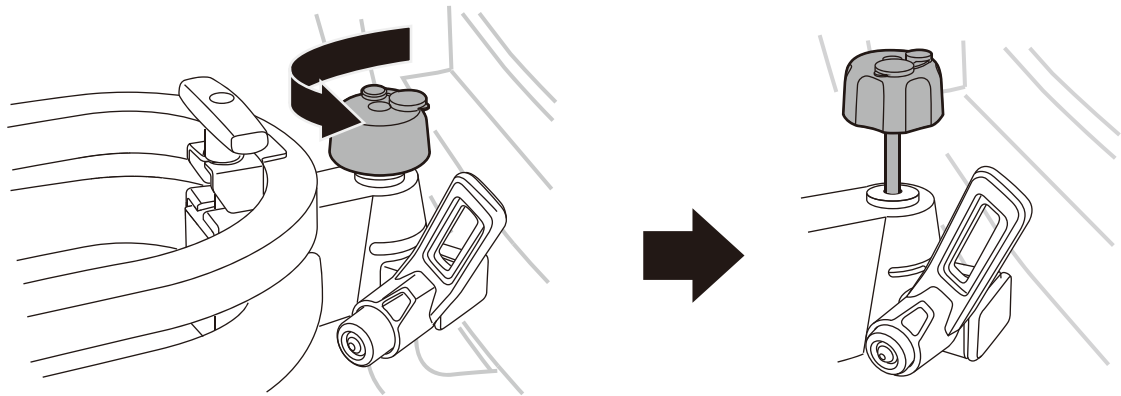

5

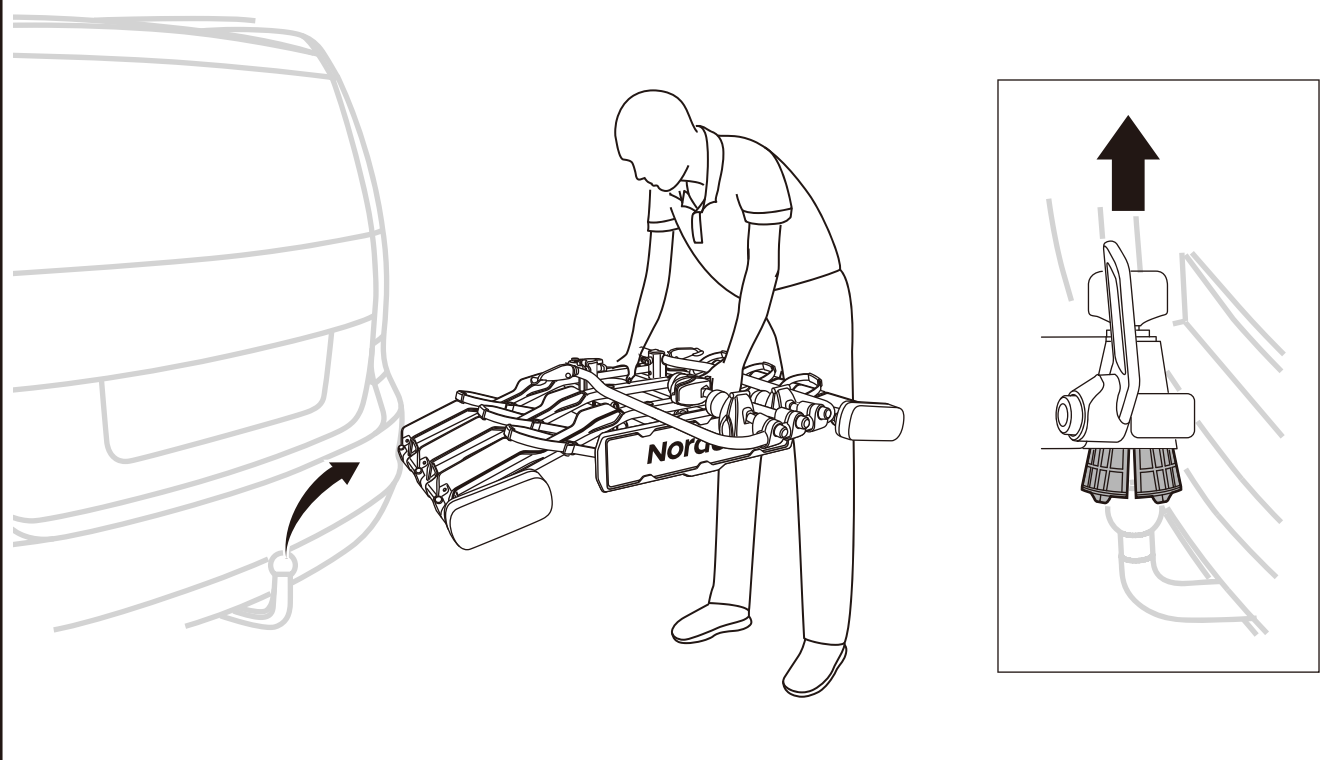

NORAUTO  
511/589 rue des Seringats 59262 Sainghin-en-Mélantois France  
www.norauto.com  
www.otu.eu  
Made in Taiwan / Fabricado en/na Taiwan / Fabriqué à Taiwan

