

Norauto

PORTE-VÉLOS D'ATTELAGE
FIETSDRAGER VOOR OP
TREKHAAK
FAHRRADHECKTRÄGER
ANHÄNGERKUPPLUNG
PROTABICICLETAS DE
ENGANCHE
TOWABLE BICYCLE RACK
PORTABICI DA GANCIO TRAINO
PORTA-BICICLETAS DE ENGATE

E-FIT 200-2

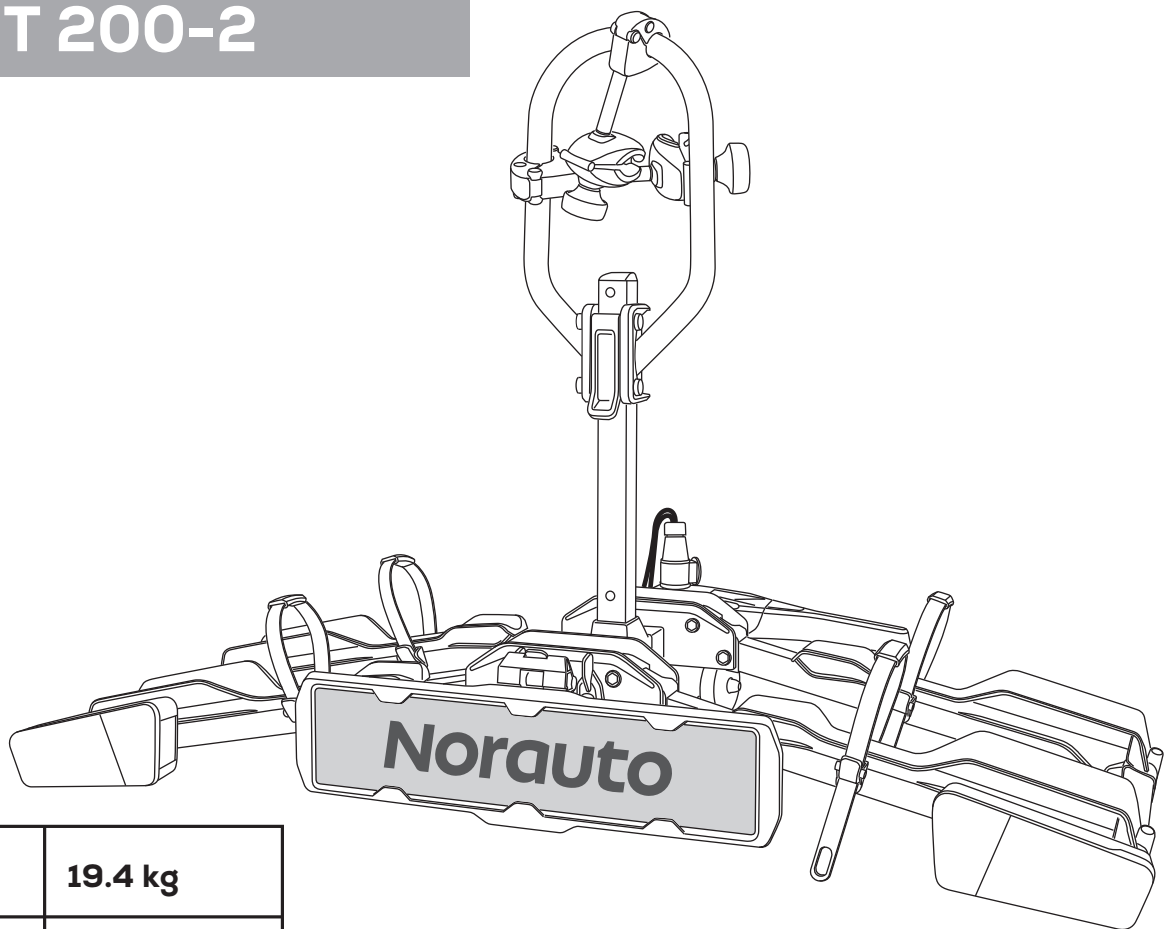

	19.4 kg
	a: >65mm b: Ø50mm
	MAX 2x30 kg

Lisez impérativement le manuel d'utilisation avant toute utilisation du produit.
De handleiding verplicht lezen voor elke ingebruikname.
Vor der Verwendung des Produkts ist diese Bedienungsanleitung aufmerksam durchzulesen.
Es esencial leer el manual antes de usar el producto.
It is essential to read the manual before use.
È essenziale leggere il manuale prima dell'uso.
Leia o manual do utilizador antes de utilizar o produto.

ART: 2543896-NO1042

FR - Notice d'utilisation / **NL** - Gebruiksaanwijzing
DE - Bedienungsanleitung / **ES** - Instrucciones
EN - User manual / **IT** - Istruzioni per l'uso
PT - Instruções de utilização





**PIÈCES / WISSELSTUKKEN / TEILE / PIEZAS / PARTS/
PEZZI / PEÇAS**

x1

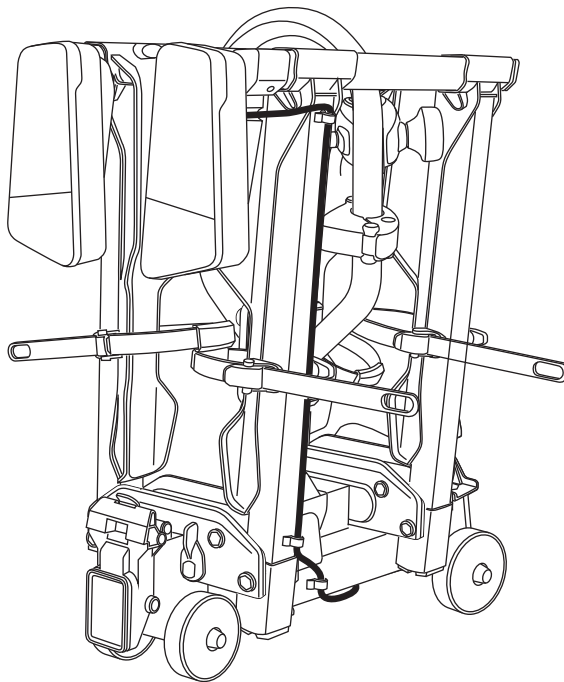

x1

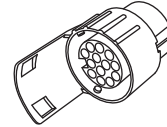

x1



x1

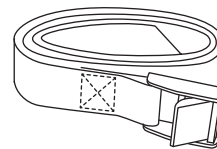

x1

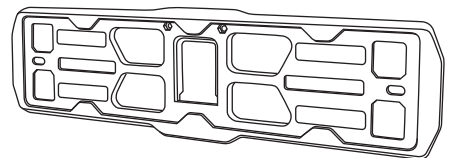

**ASSEMBLAGE DU PORTE-VÉLOS / DE PRODUCTIE VAN DE FIETSENDRAGER
MONTAGE DES FAHRRADTRÄGERS / ENSAMBLAJE DEL PORTABICIS
ASSEMBLY OF THE BICYCLE RACK / ASSEMBLAGGIO DEL PORTABICI
MONTAGEM DO PORTA-BICILETAS**

1

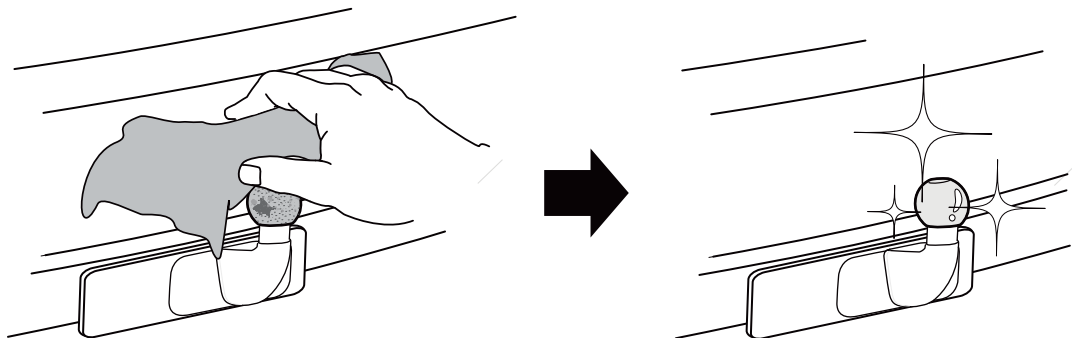

2

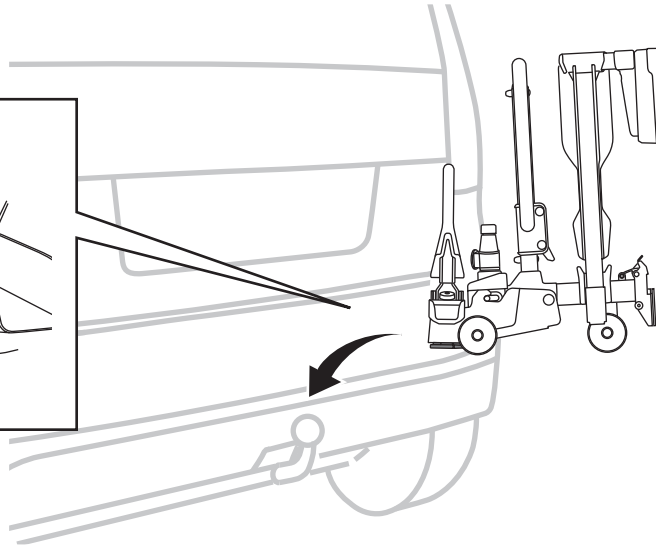
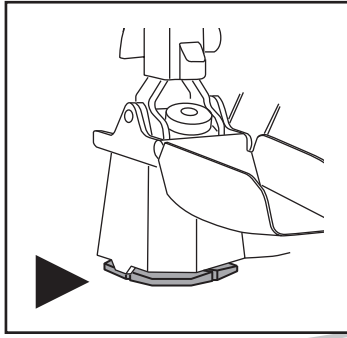

3

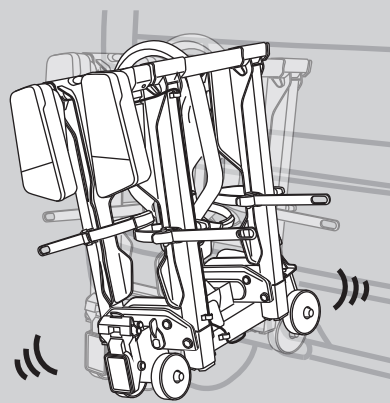
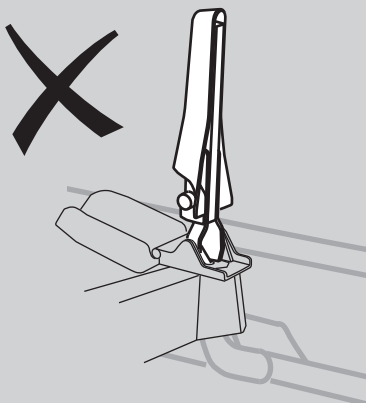
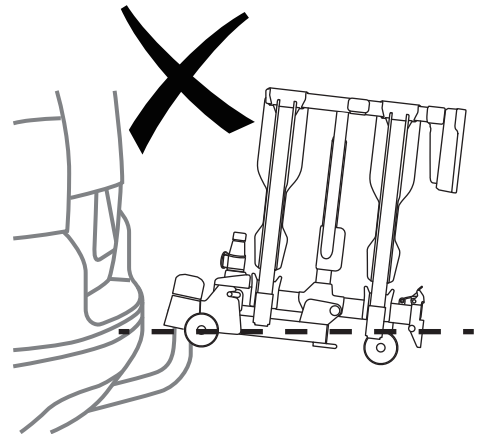
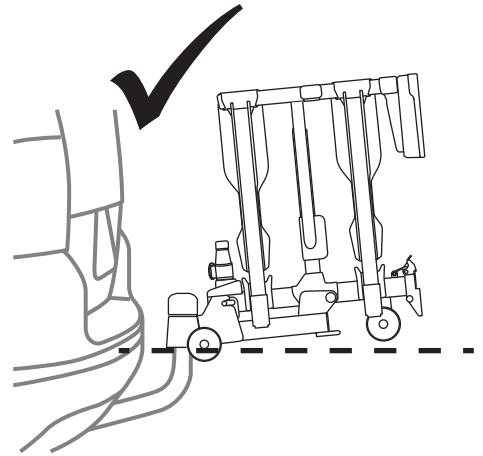
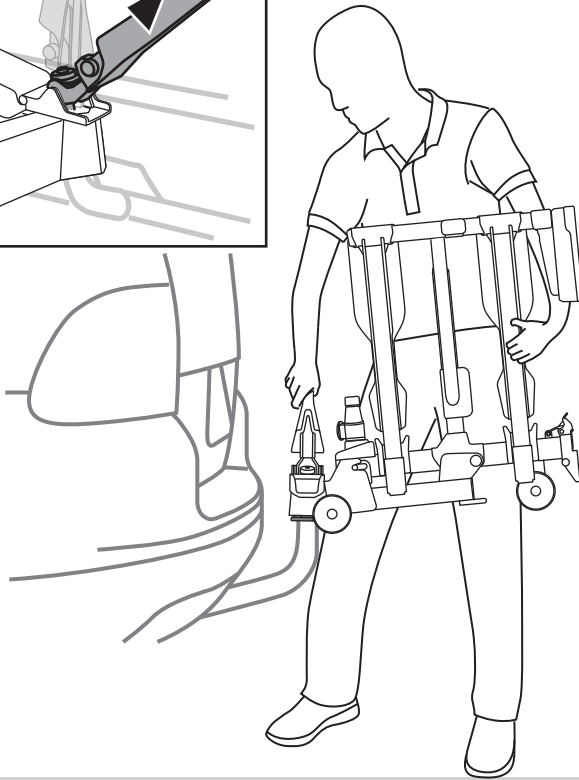
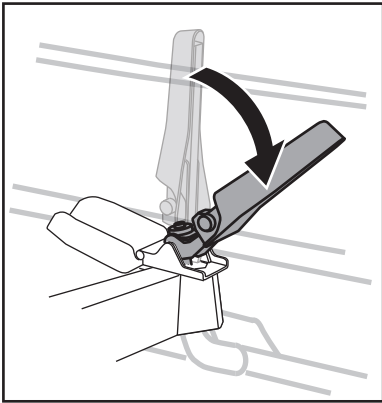

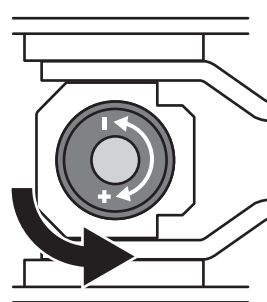
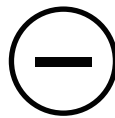
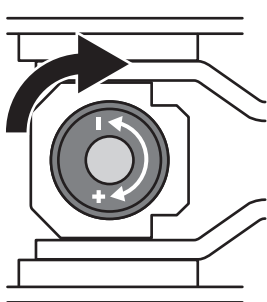
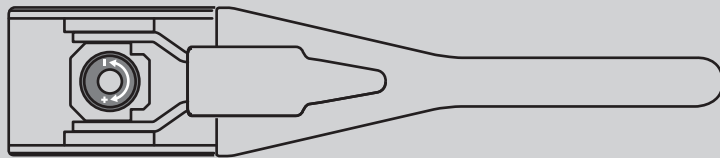
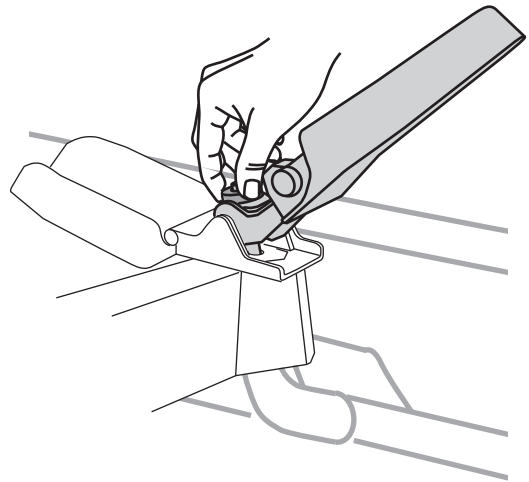
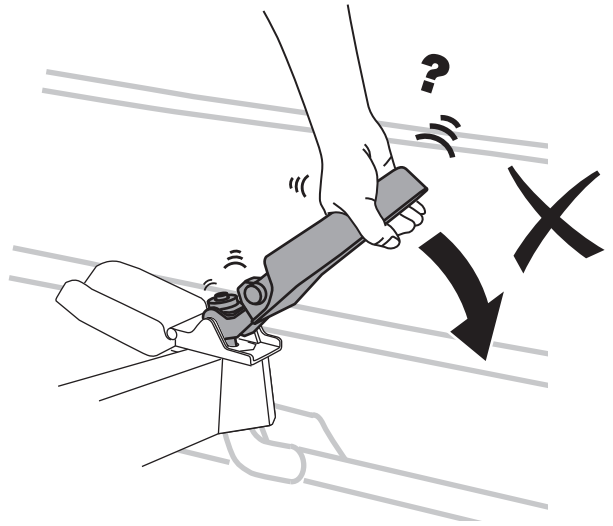
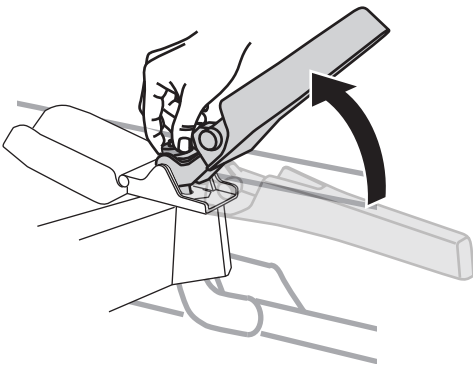
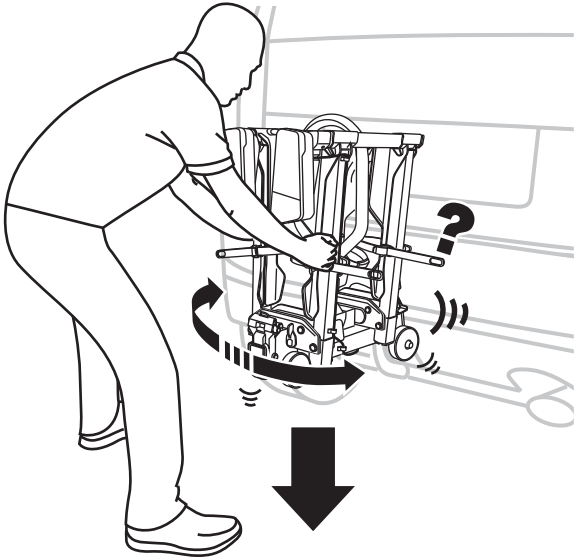
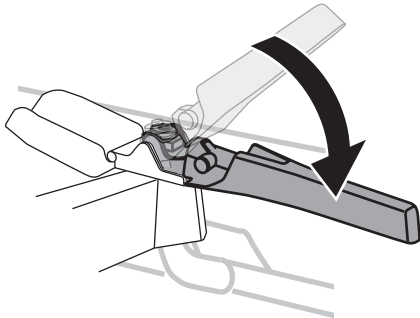

5

! MAX
70 Kg

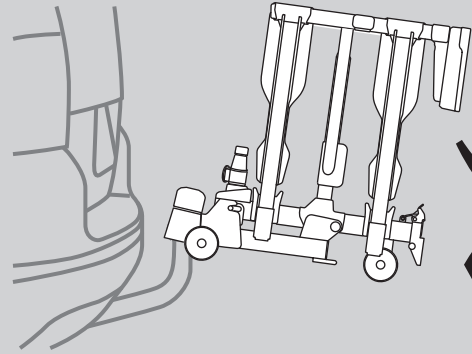
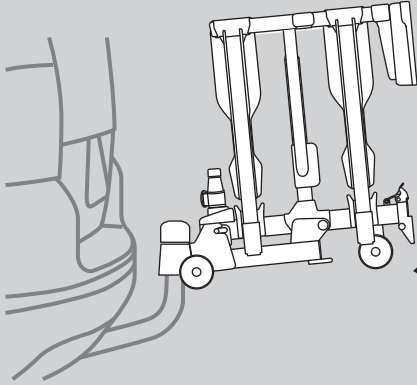
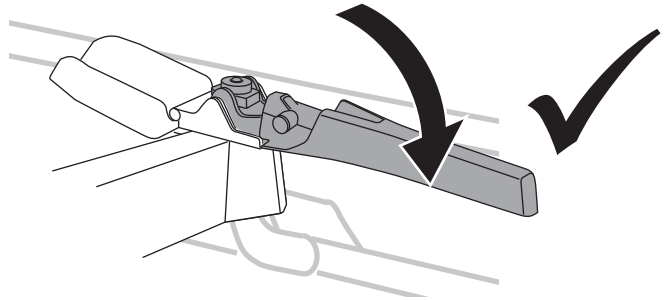

6

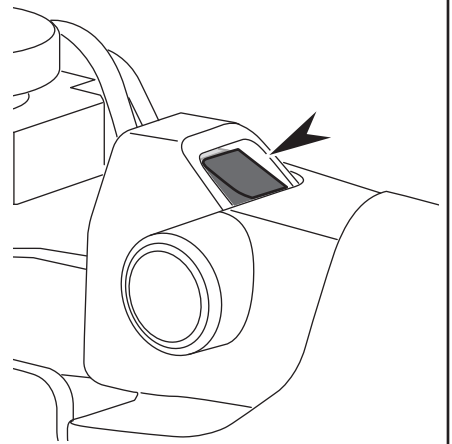
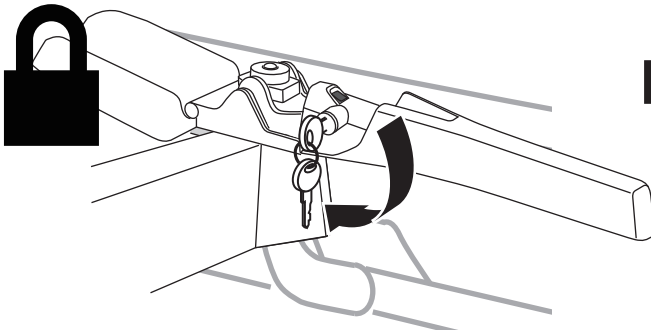

7

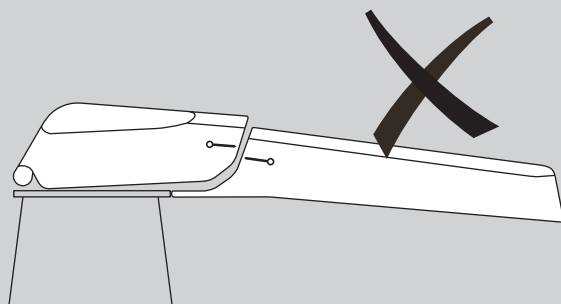
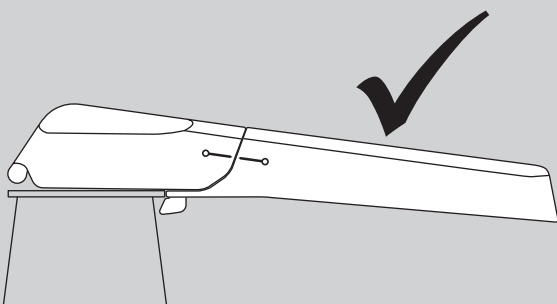
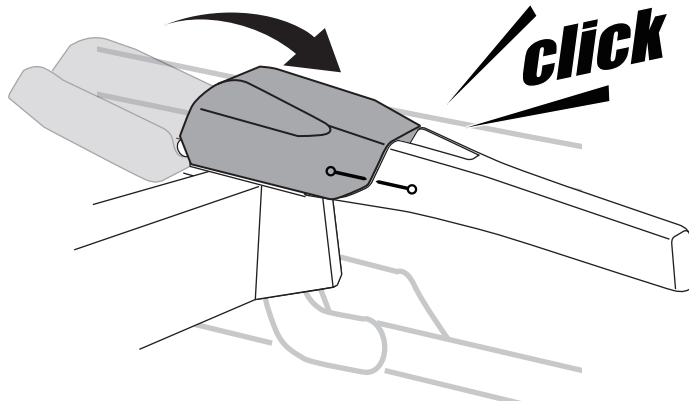

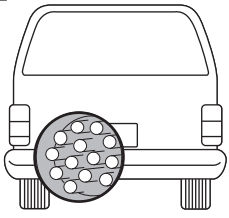

13-pin

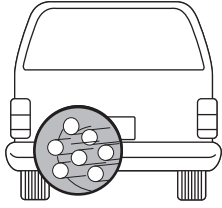
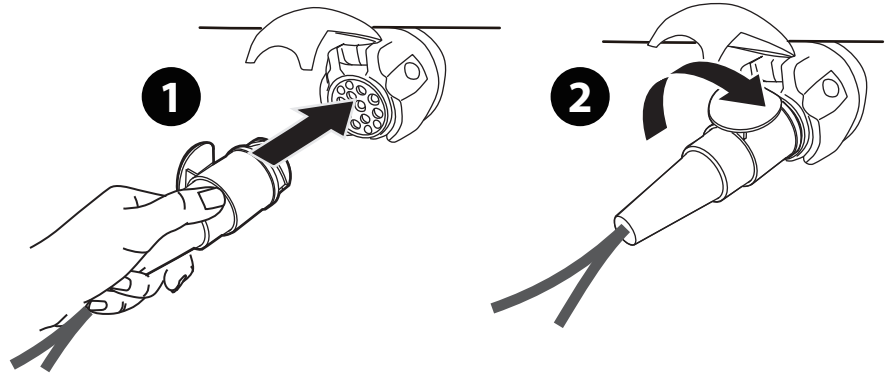

7-pin

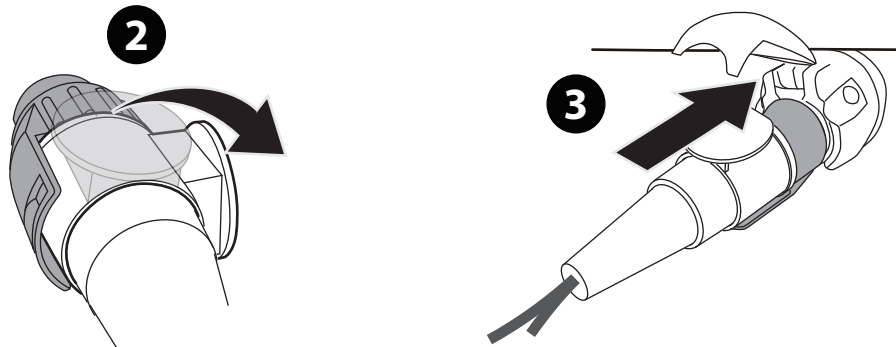
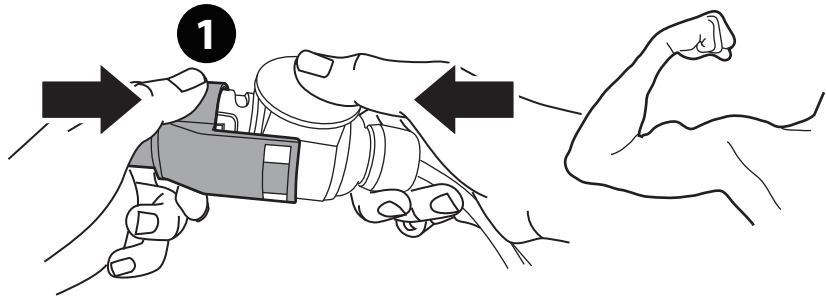
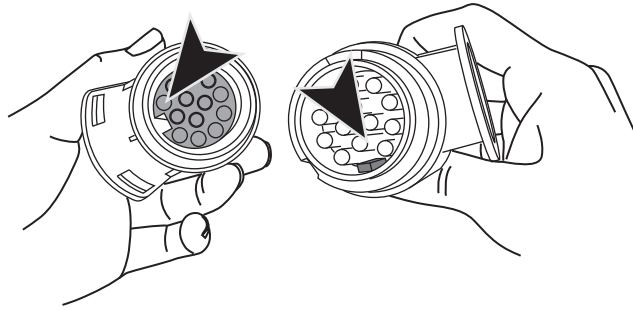
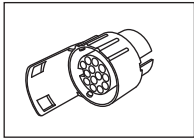

9

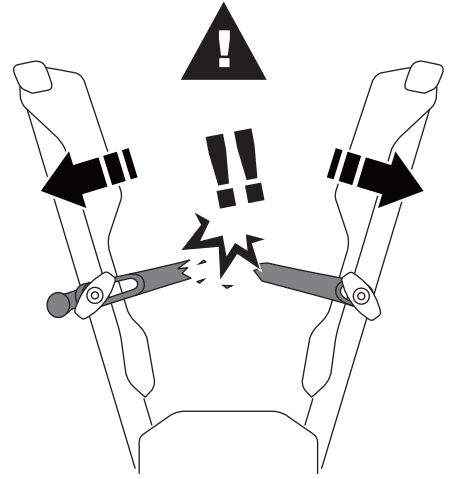
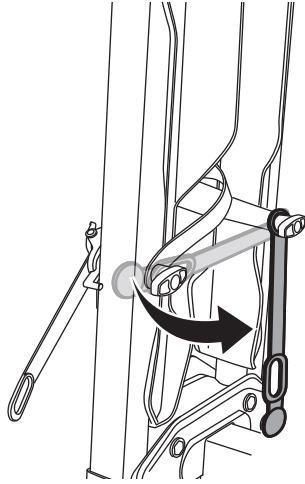
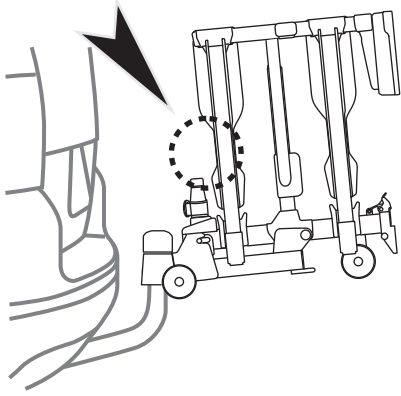

10

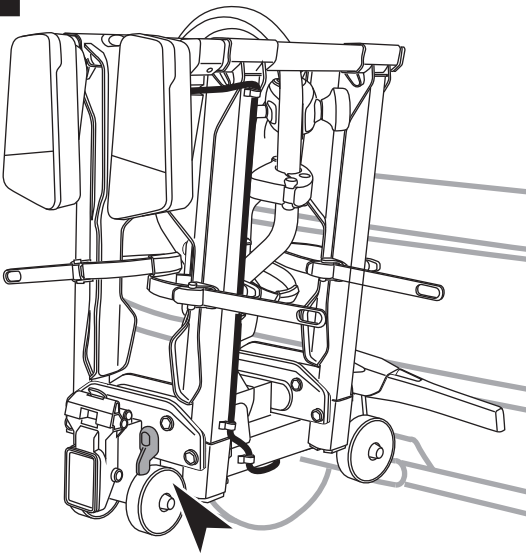

1

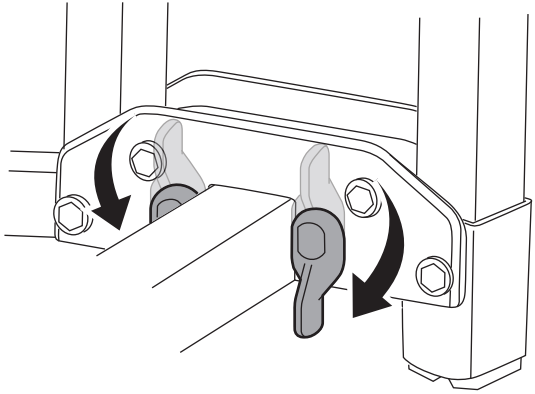

2

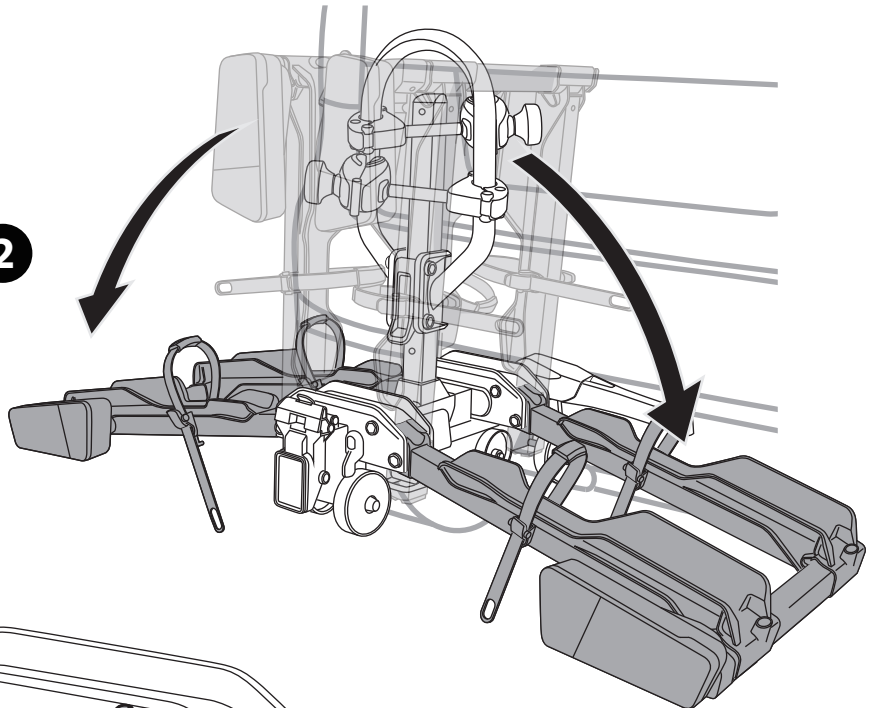

3

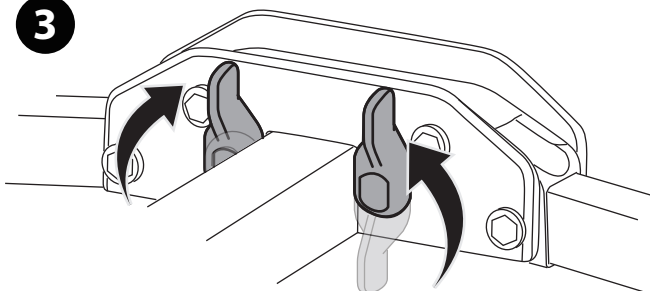

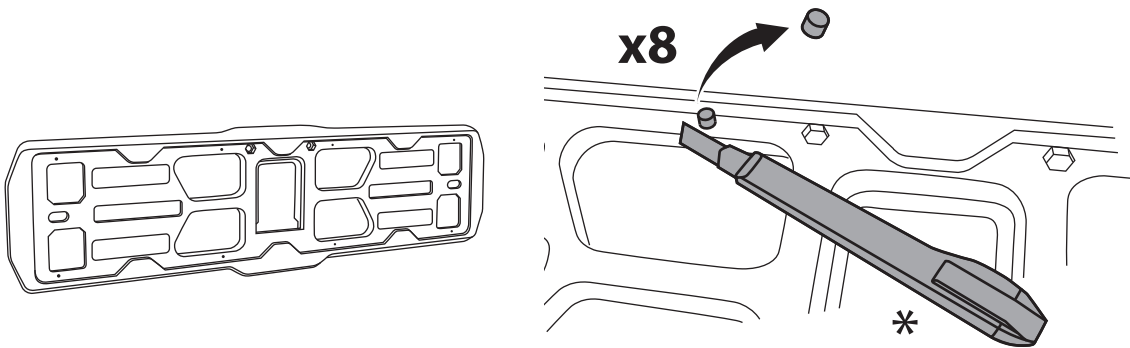
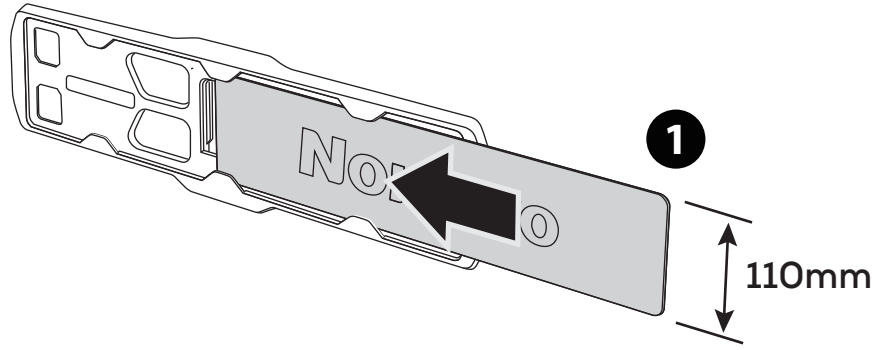

* This tool is not included.

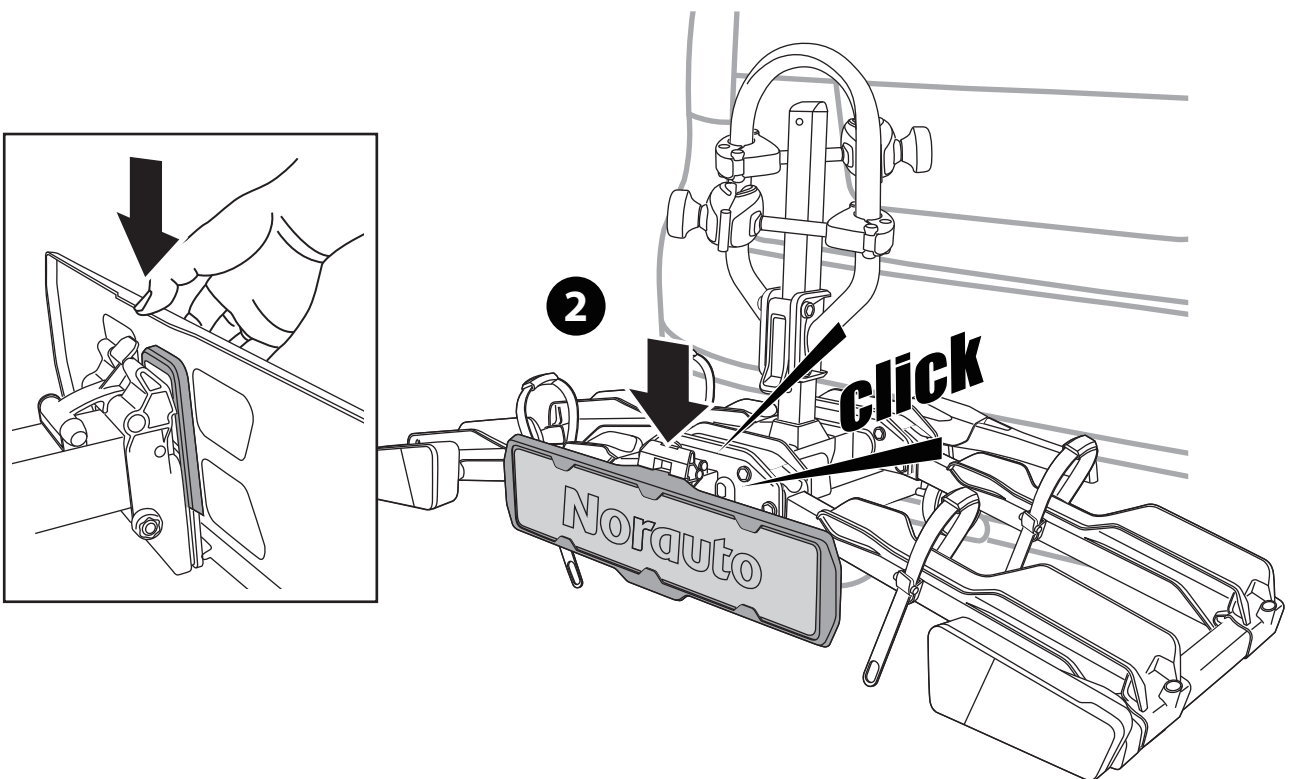

**MONTAGE DES VÉLOS / MONTAGE VAN DE FIETSEN
 MONTAGE DER FAHRRÄDER / MONTAJE DE LAS BICICLETAS
 BICYCLES MOUNTING/ MONTAGGIO DELLE BICI
 MONTAGEM DAS BICICLETAS**

1

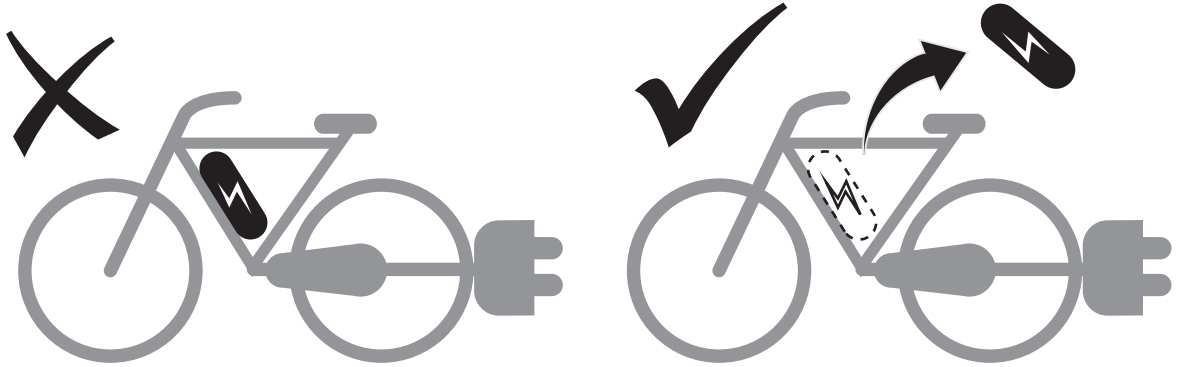

2

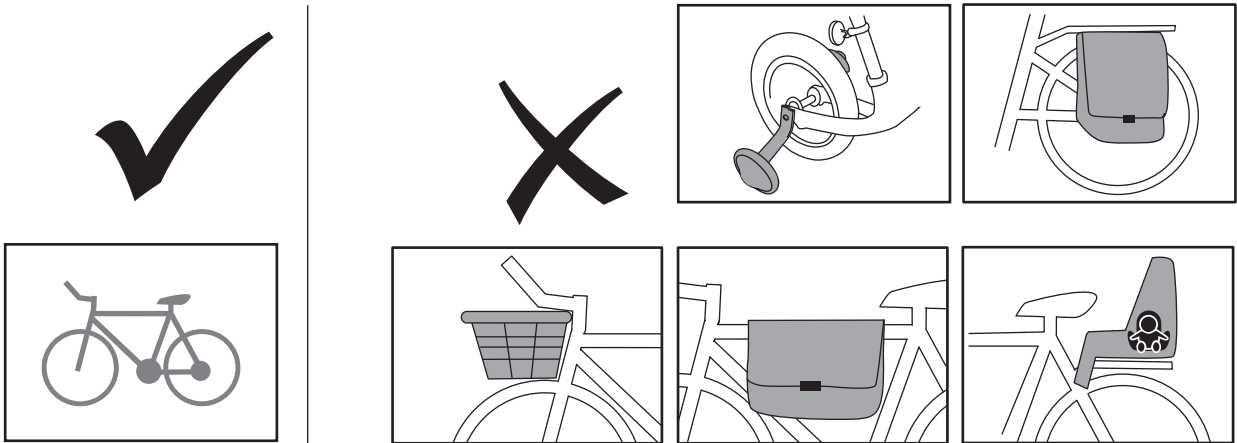

3

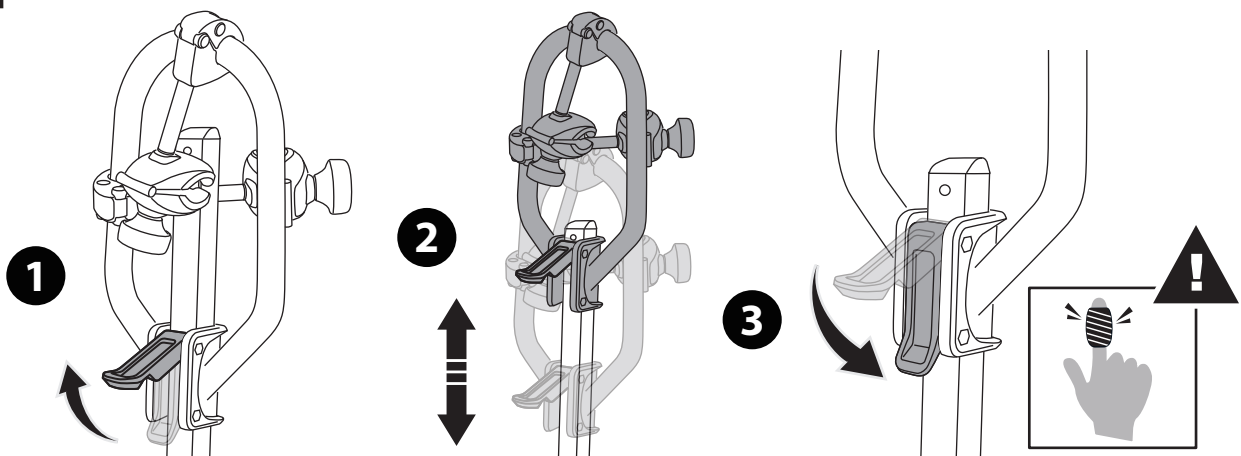

4

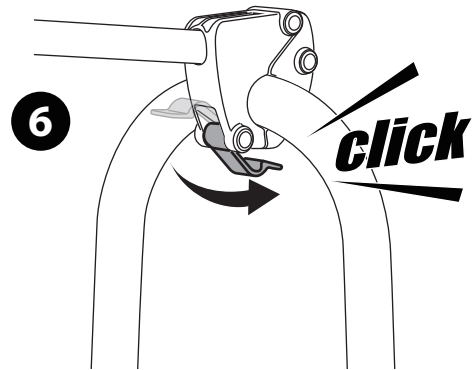
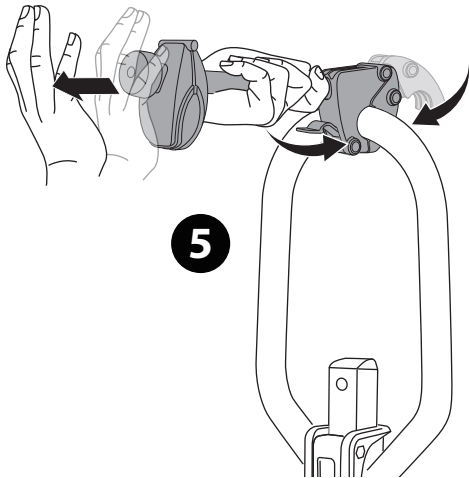
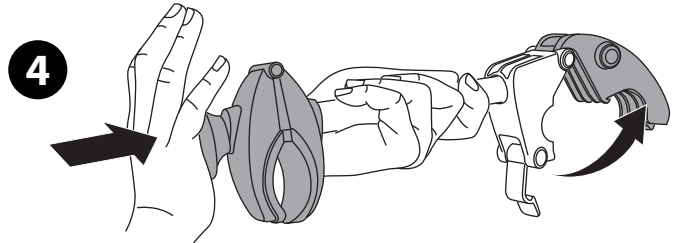
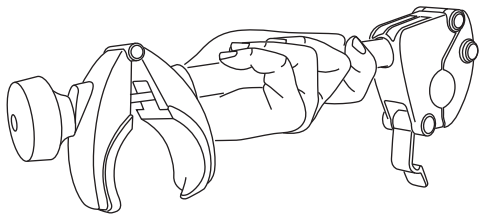
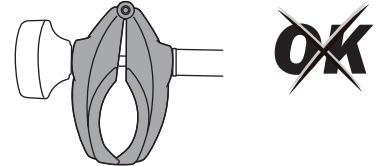
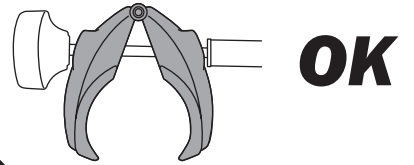
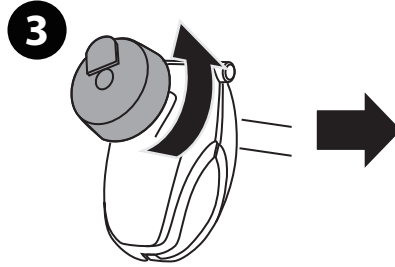
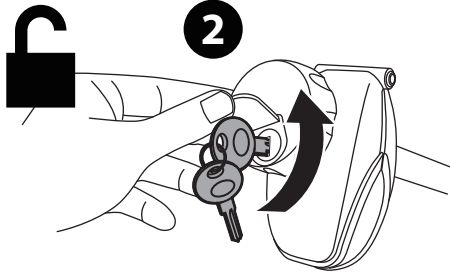
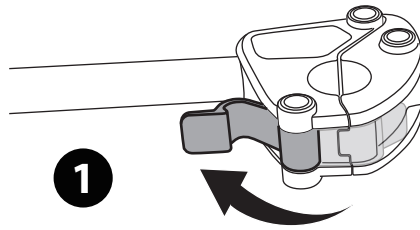
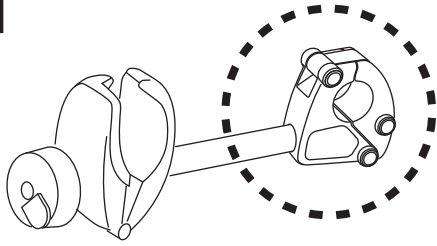

5

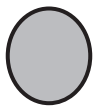

min. Ø25 mm
max. Ø60 mm

OK

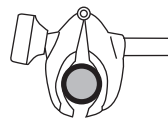

OK

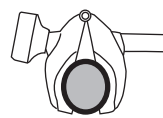

~~OK~~

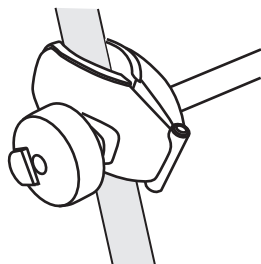
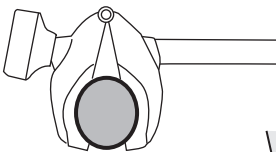

OK

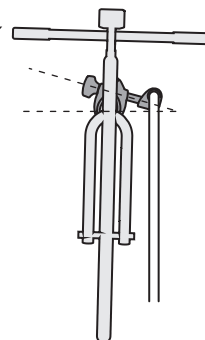

~~OK~~

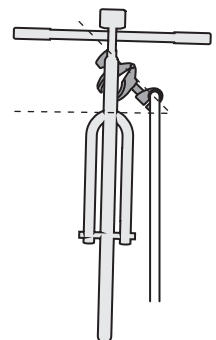



Ne pas dépasser la valeur de serrage pour les vélos cadre carbone.
 Überschreiten Sie den Spannwert für Fahrräder mit Carbonrahmen nicht.
 Klemwaarde niet overschrijden voor fietsen met carbonframe.
 No superar el valor de ajuste en bicicletas con cuadro de carbono.
 Do not exceed the clamping value for carbon frame bicycles.
 Non superare il valore di serraggio per le bici con telaio in carbonio.
 Não exceder o valor de aperto para bicicletas de quadro de carbono.

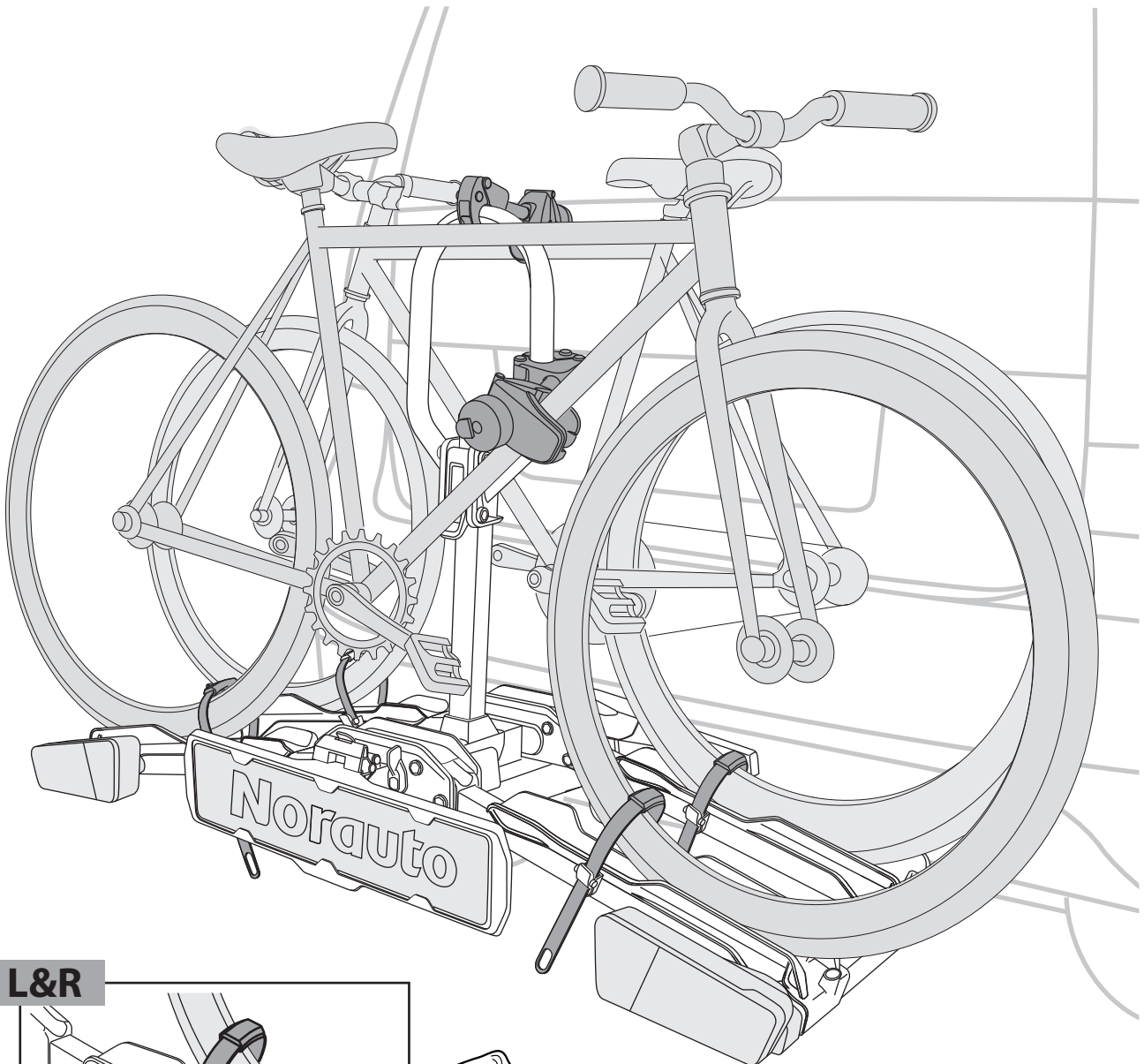
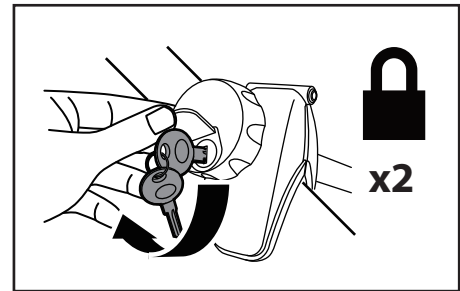
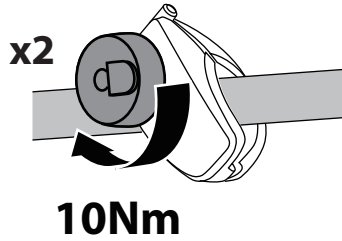

L&R

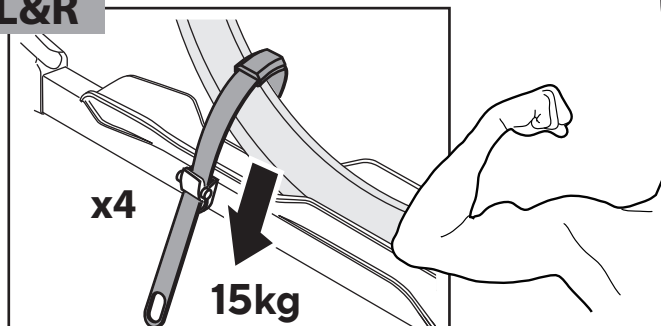

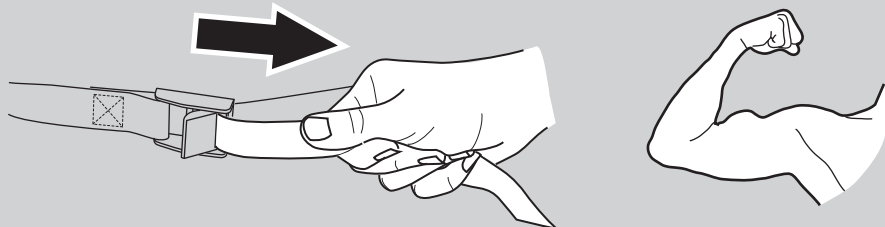
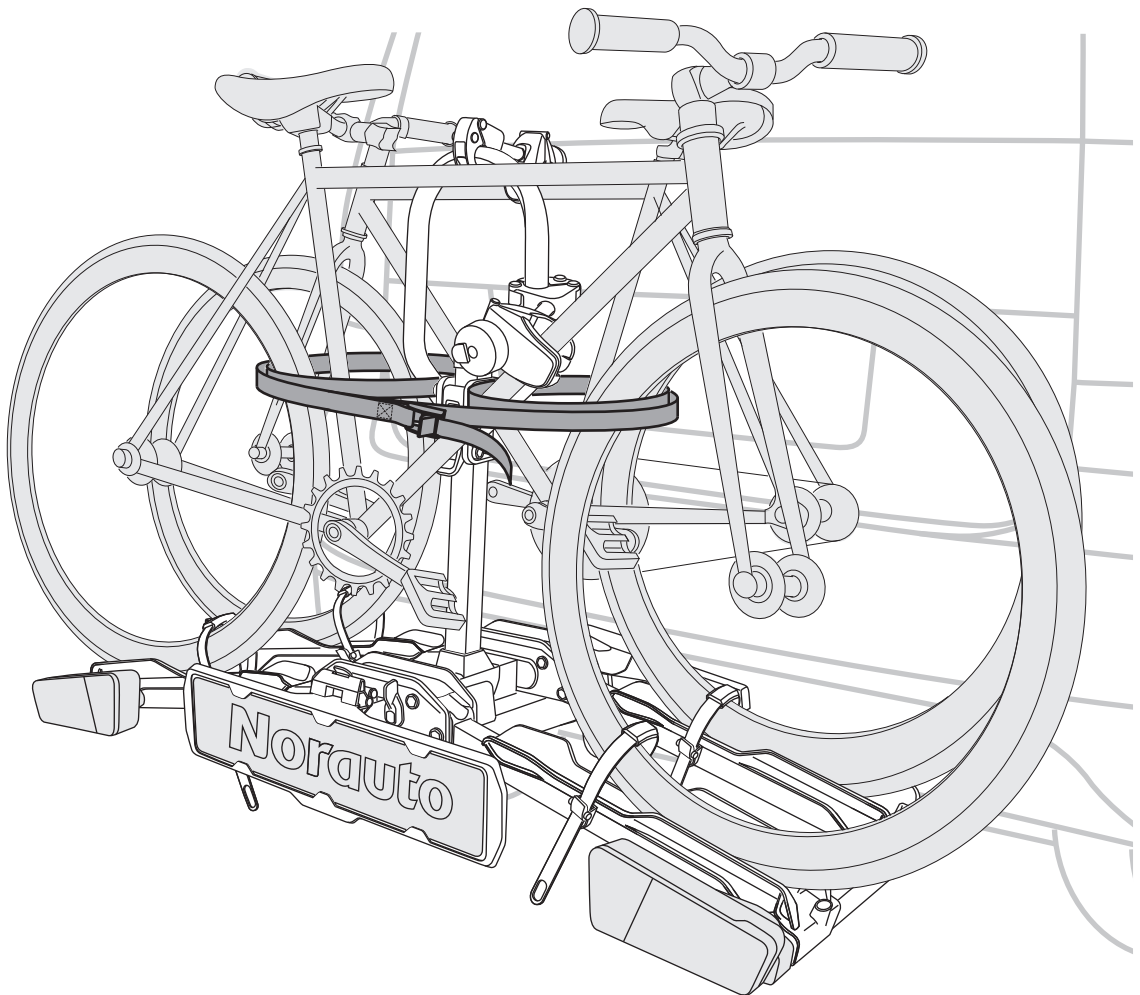
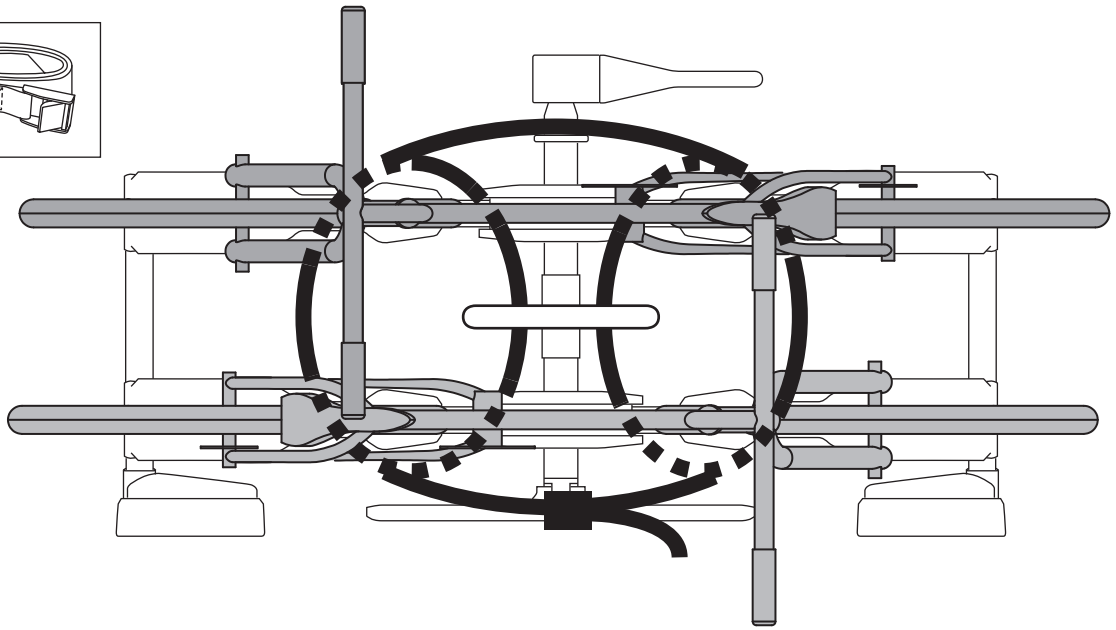
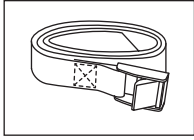

BASCULEMENT DU PORTE-VÉLOS POUR UN ACCÈS FACILITÉ AU COFFRE
KANTELEN VAN DE FIETSENDRAGER OM TOEGANG TE HEBBEN TOT DE KOFFER
ABKLAPPEN DES FAHRRADTRÄGERS ZUM ÖFFNEN DES KOFFERRAUMS
EL PORTABICIS BASCULA PARA PODER ACCEDER AL MALETERO
TILTING OF THE BICYCLE RACK FOR AN EASY ACCESS TO THE TRUNK
PORTABICI BASCULANTE PER ACCEDERE AL BAULE
BASCULAR O PORTA BICICLETAS PARA ACEDER À MALA

1

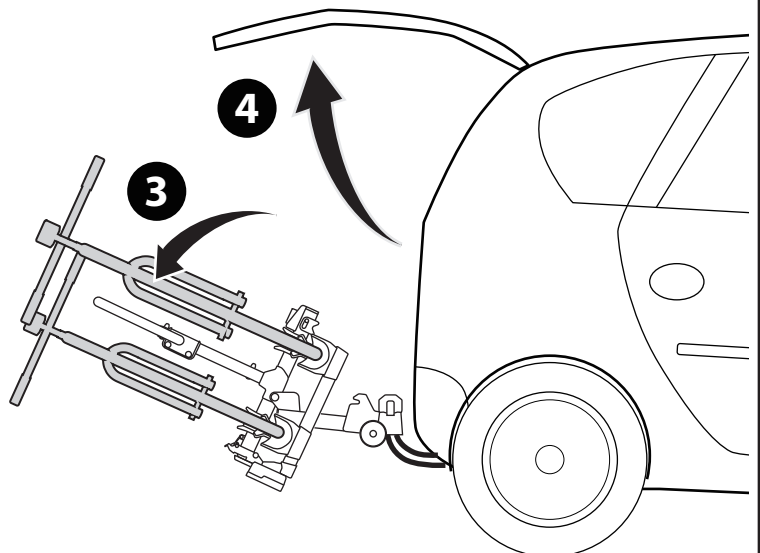
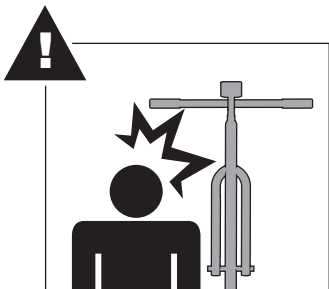
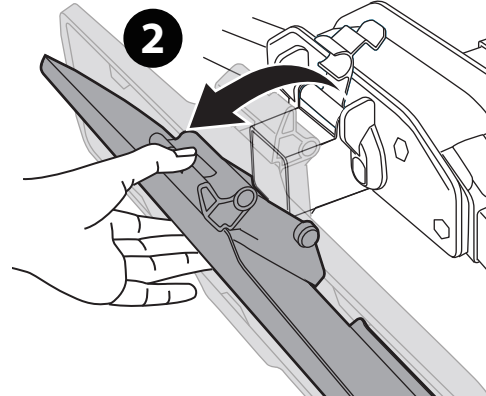
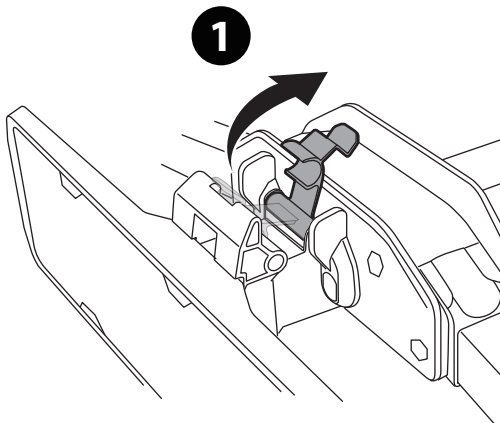
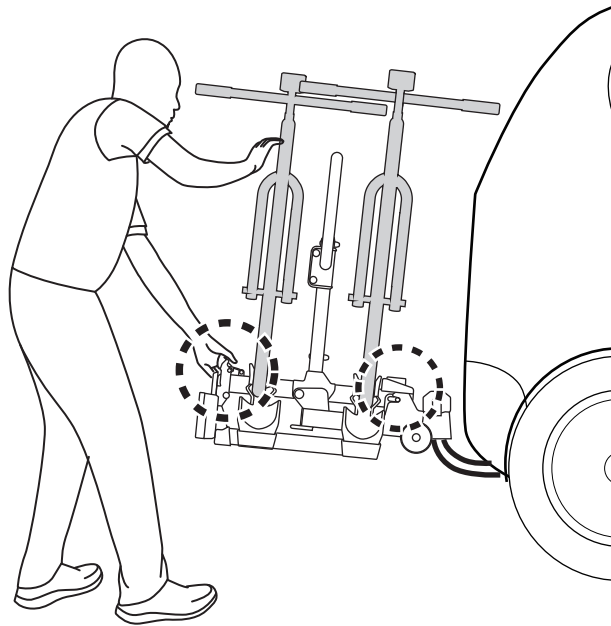

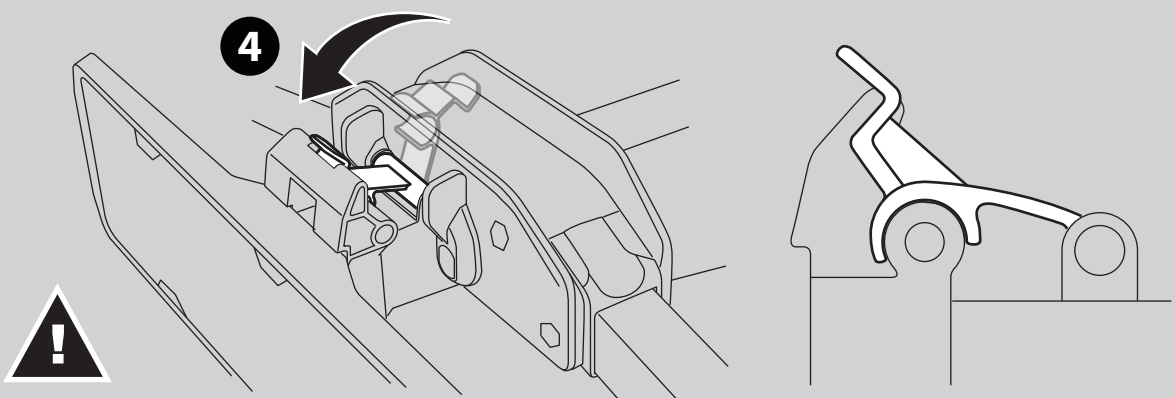
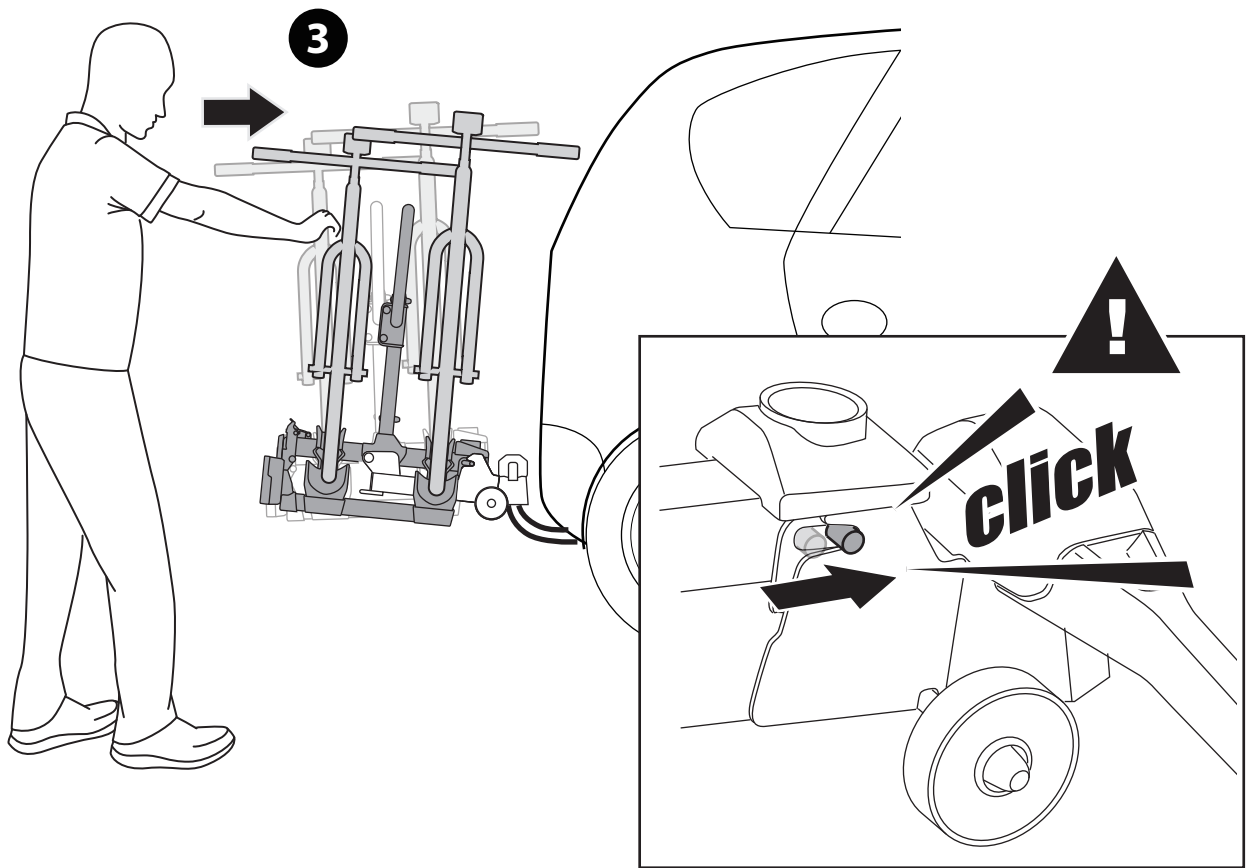
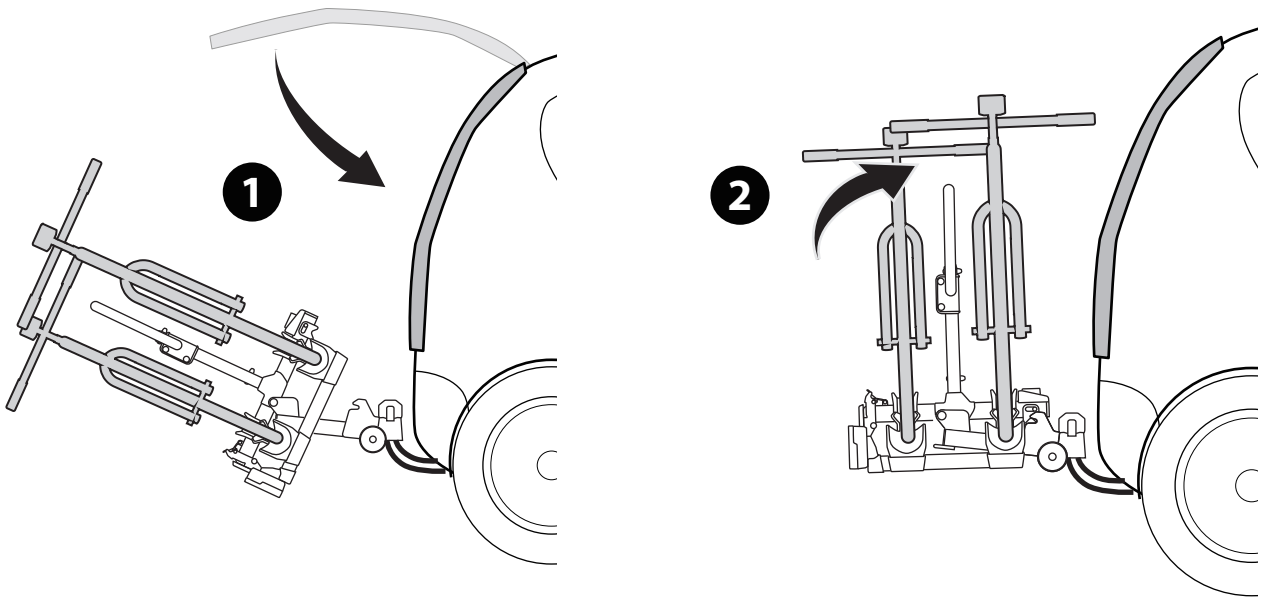

DEMONTAGE / ABMONTIEREN / DESMONTAJE / DISASSEMBLY
SMONTAGGIO / DESMONTAGEM

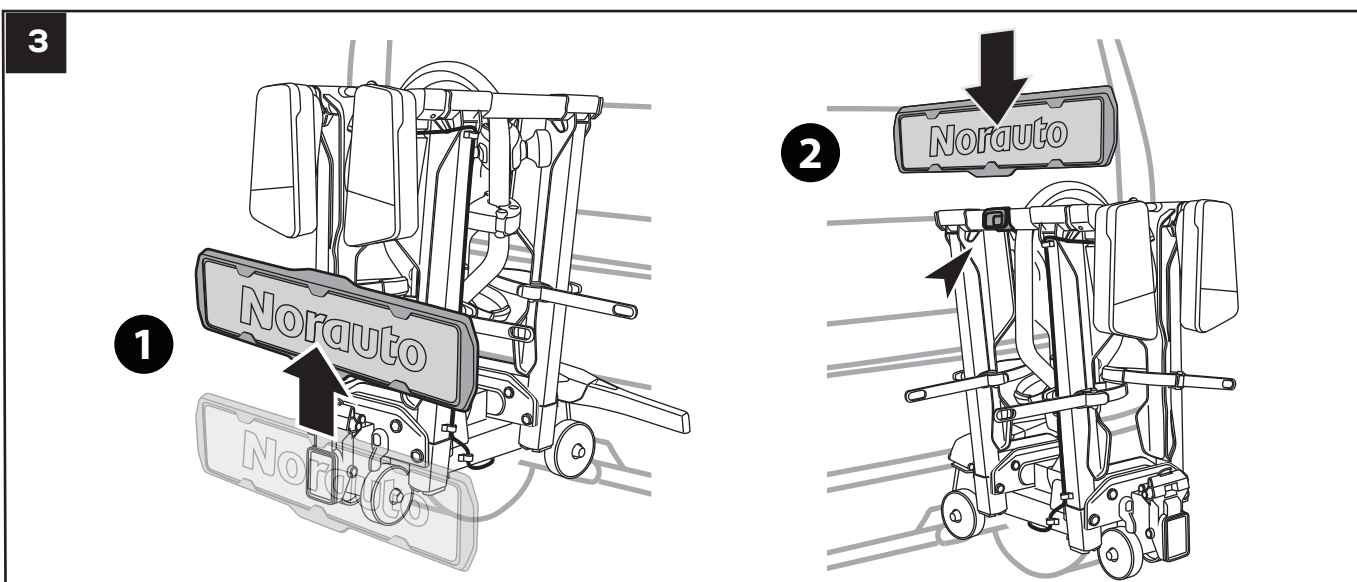
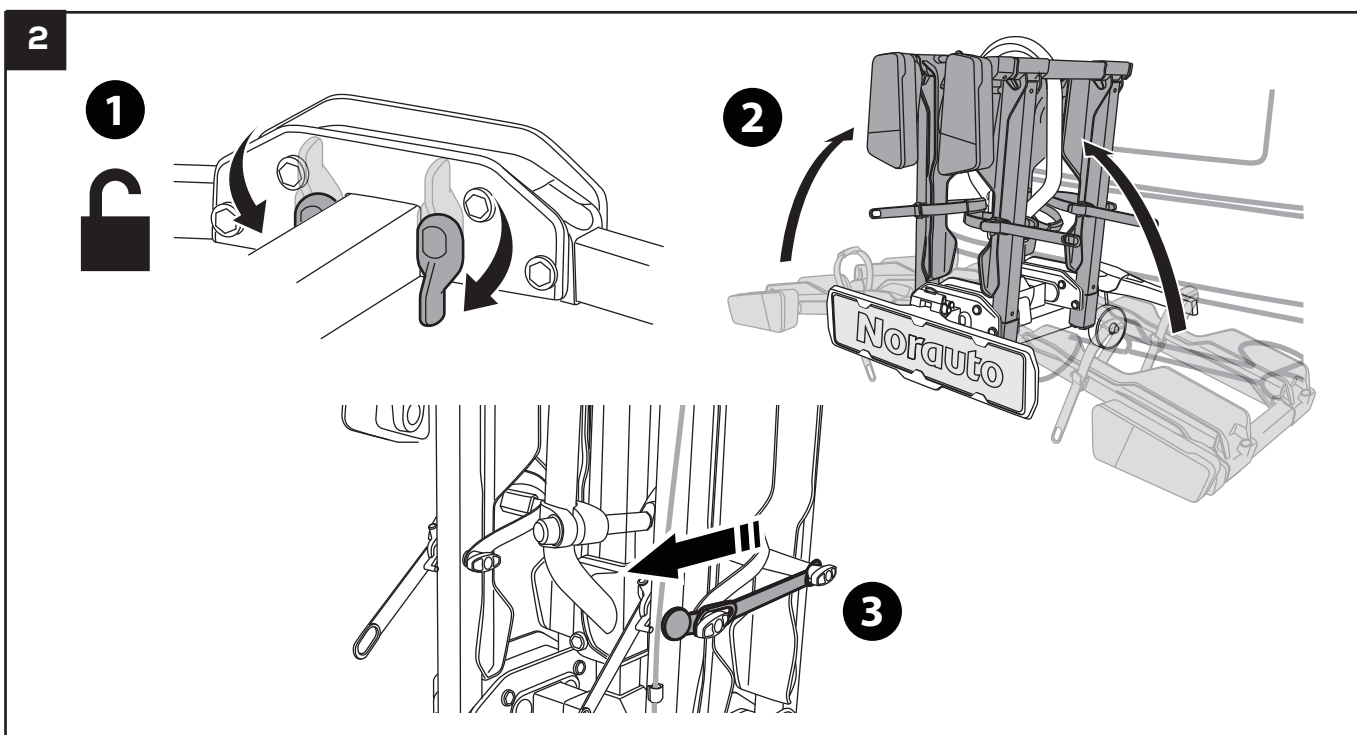
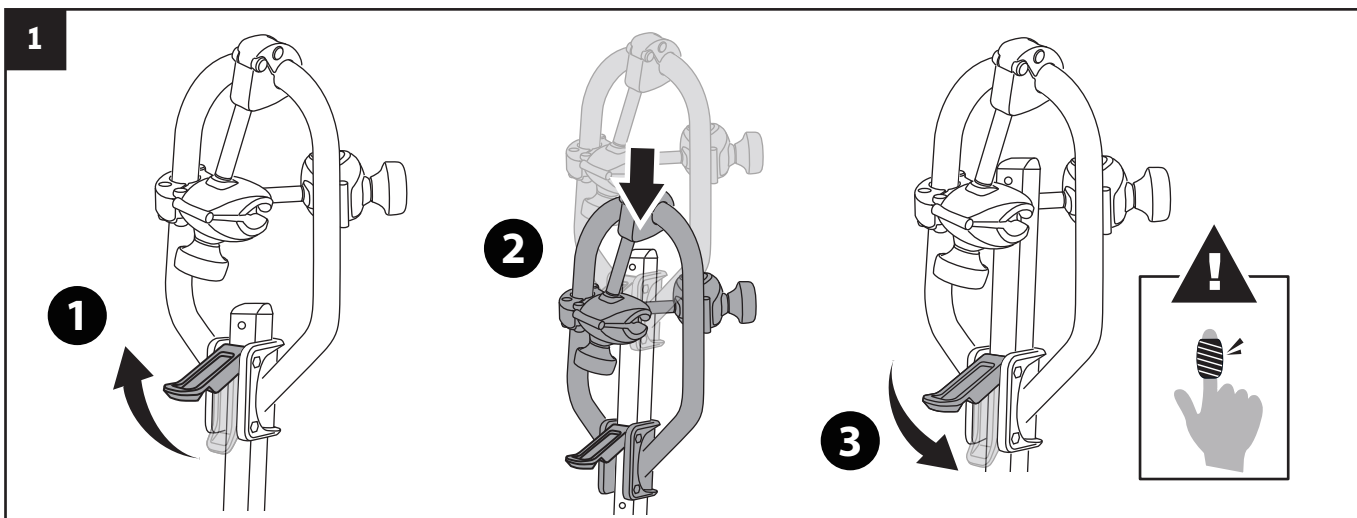

4

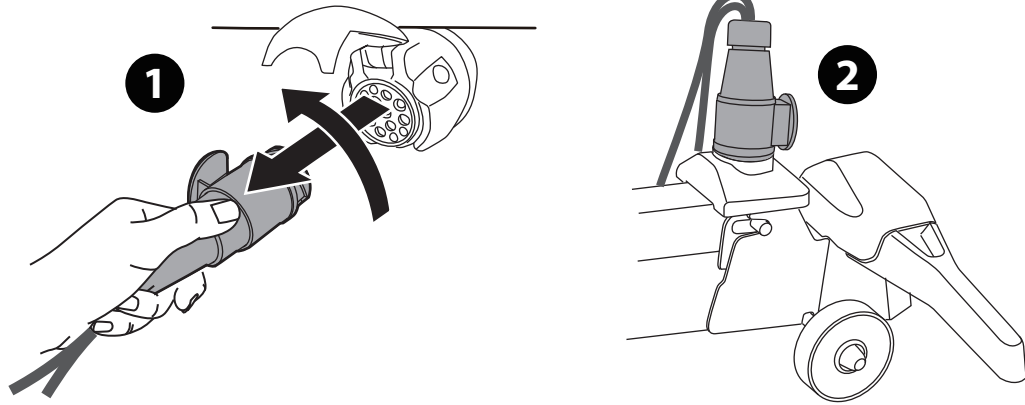

5

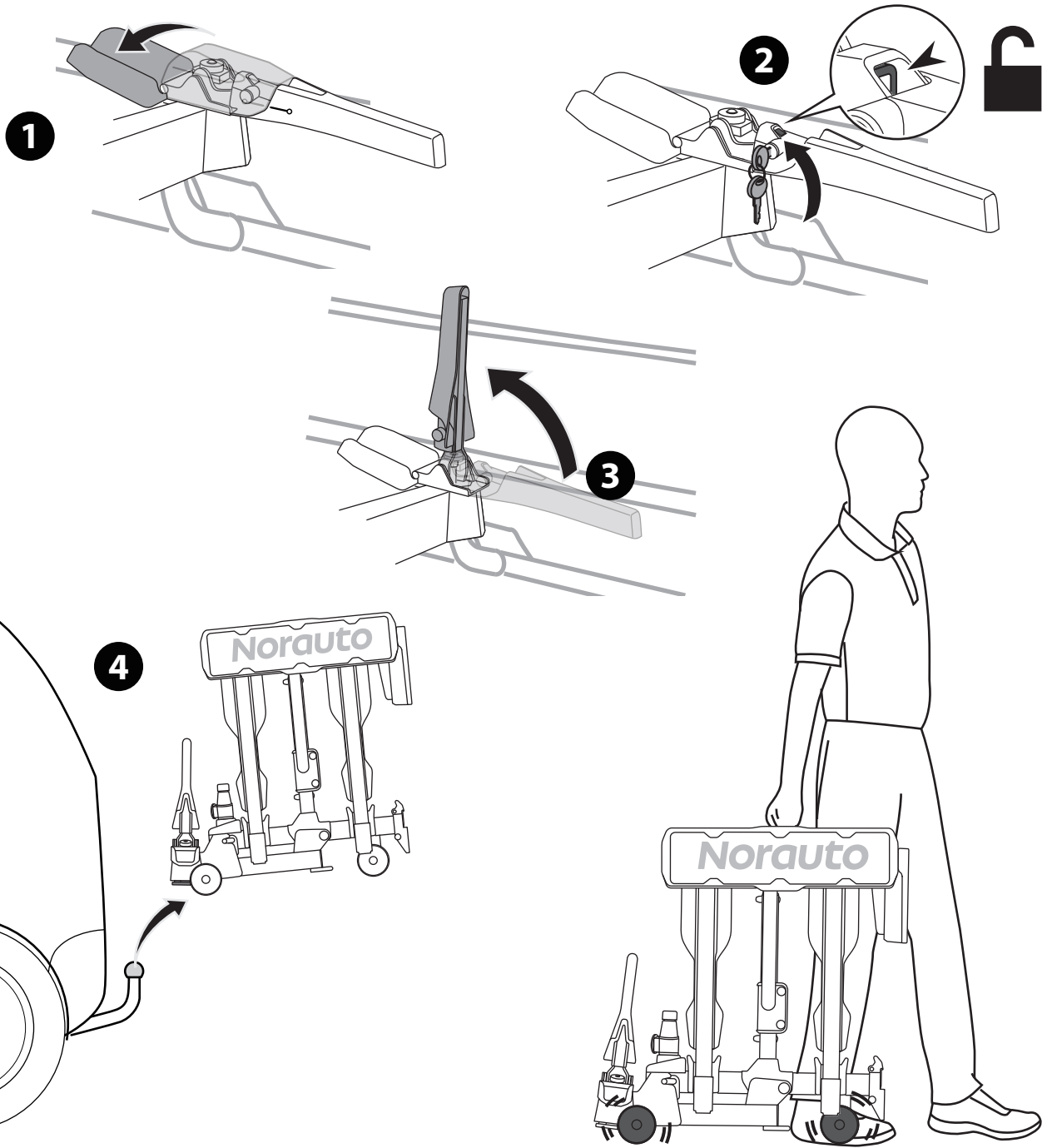

NORAUTO
 2A boulevard Van Gogh 59650 Villeneuve d'Ascq France
 www.norauto.com
 www.atu.eu
 Made in Taiwan / Fabricado en/na Taiwan / Fabriqué à Taiwan



MANUALE
PAP 22
CARTA
 RACCOLTA CARTA
 VERIFICA LE DISPOSIZIONI
 DEL TUO COMUNE