

Fitting instructions

Make: Hyundai

Santa Fe (CM); 2006->

Type: 4659

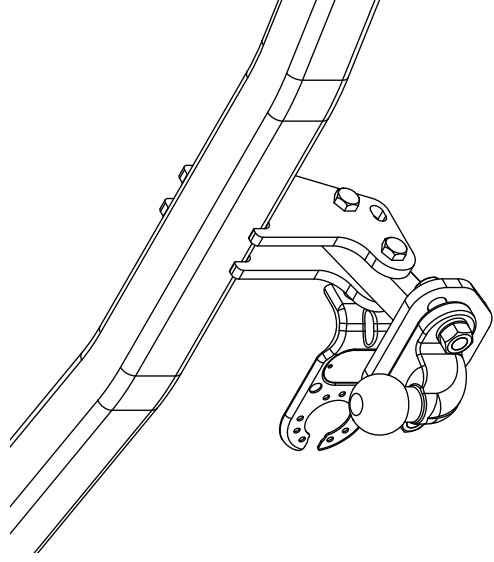
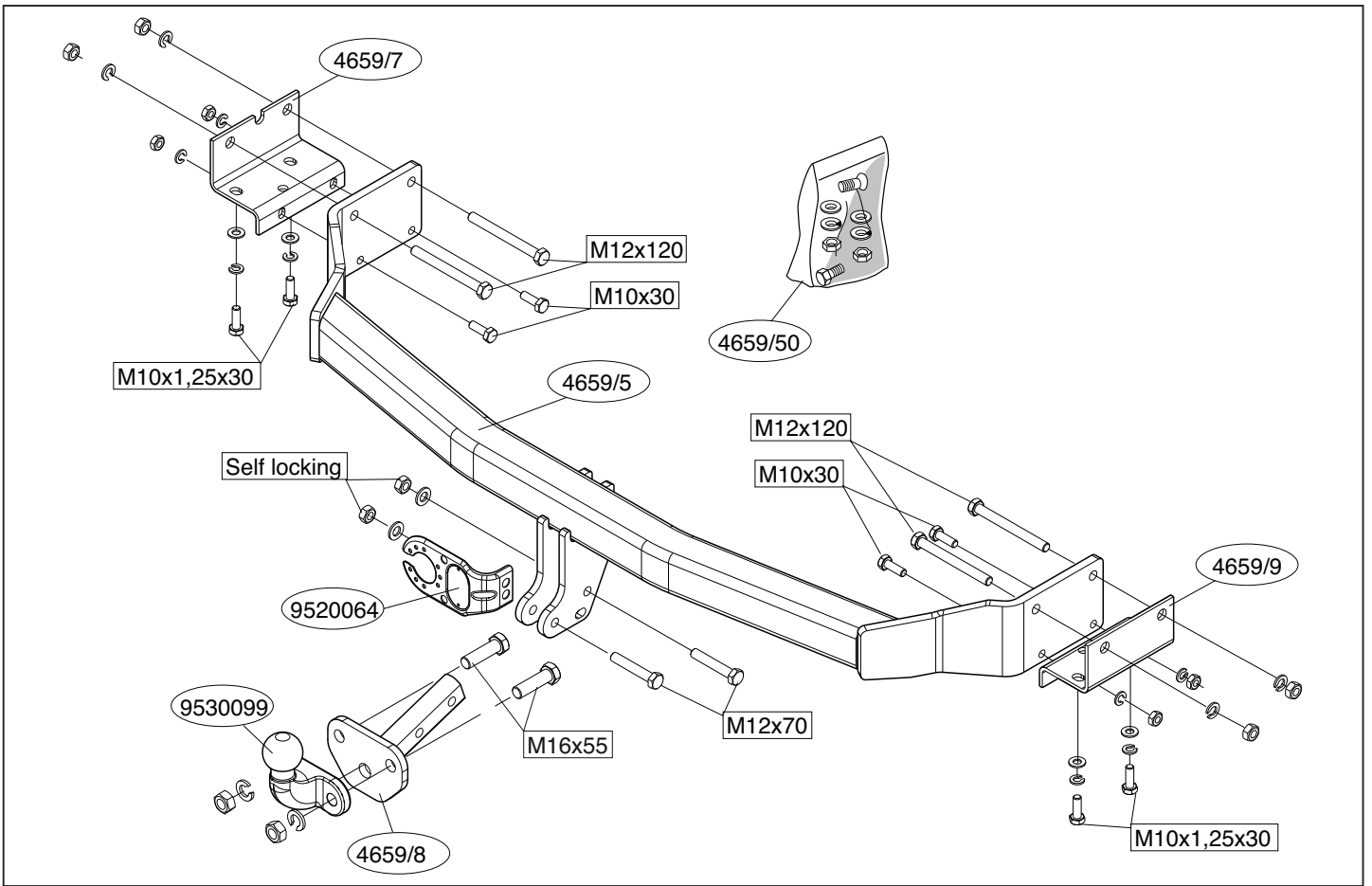





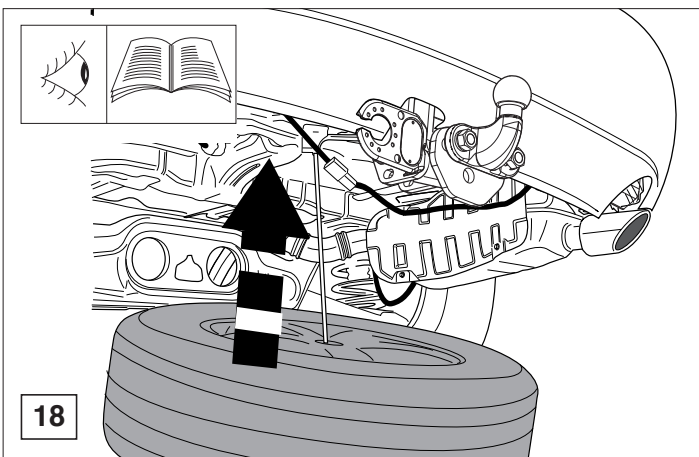
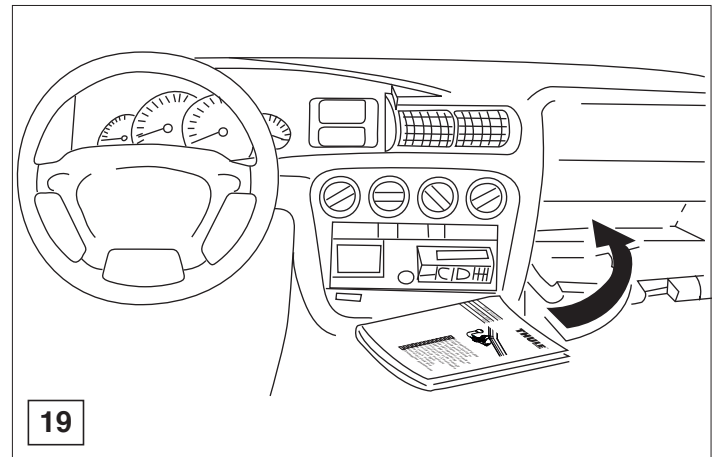
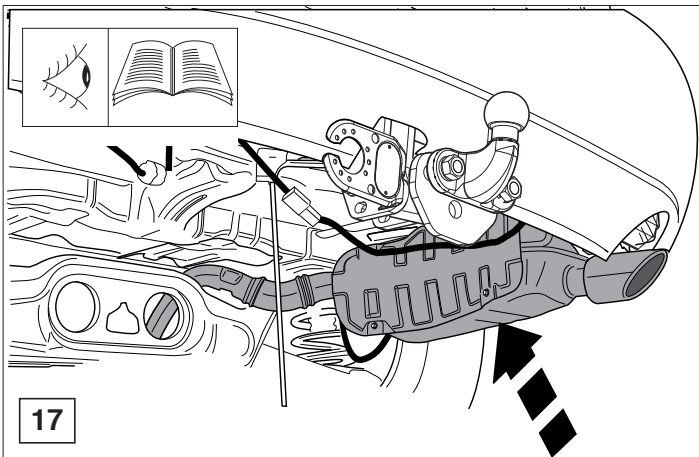













© 465970/18-06-2008/1



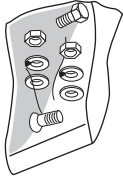
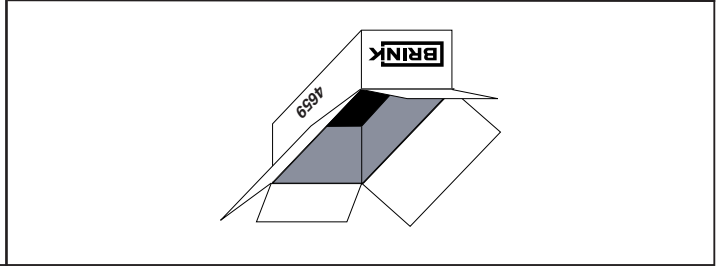
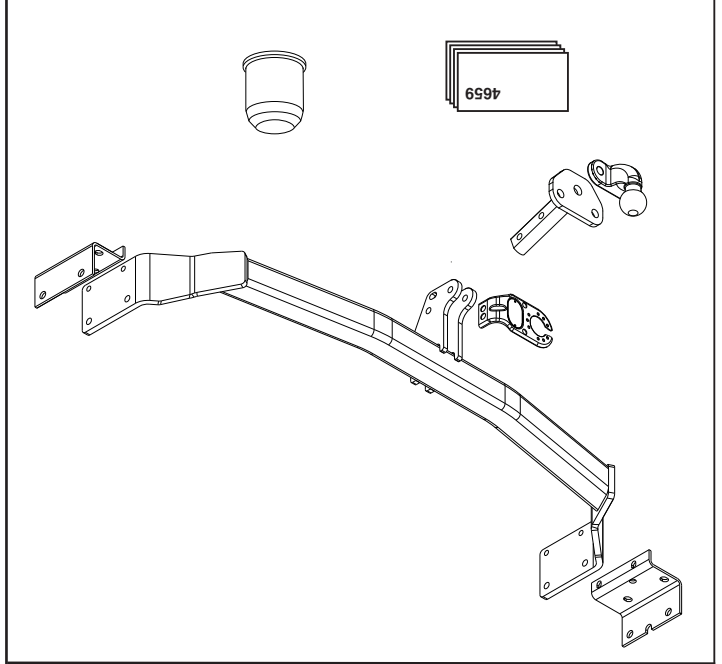

© 465970/18-06-2008/14

(2x) M16			
M12 self-locking		(2x) M16x55	
(4x) M12			
(4x) M10		(2x) M12x70	
(2x) M16		(4x) M12x120	
(8x) M10			
(4x) M12		(4x) M10x1,25x30	
(2x) M12			
(4x) M10		(4x) M10x30	













16

LHS + RHS

15

(2x) M16			
self-locking		(2x) M12	
(2x) M16		M16	
(2x) M12			
(2x) M16x55			
(2x) M12x70			

24		195 Nm
19		71 Nm

M12 (self-locking)

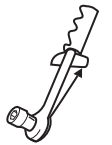

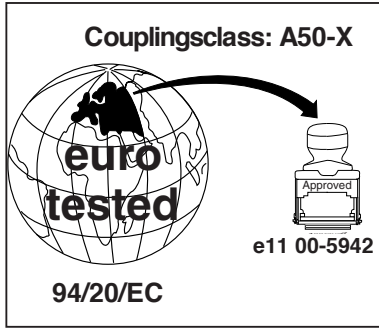
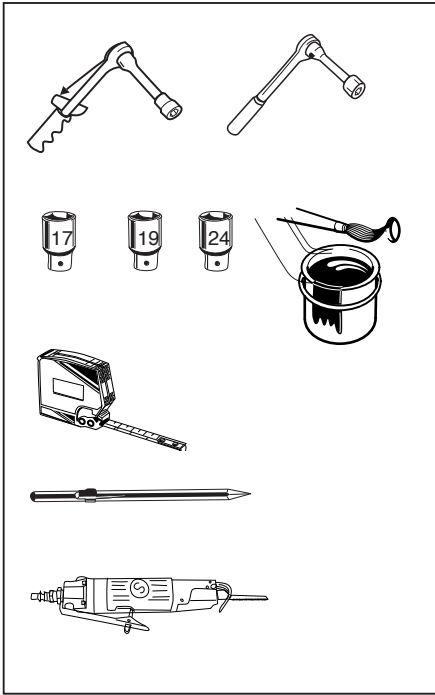

D-Value : 11,6 kN

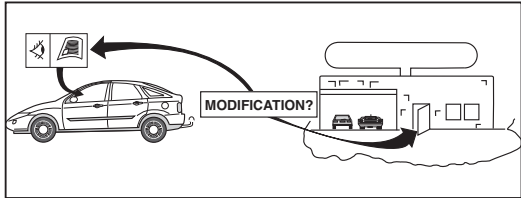
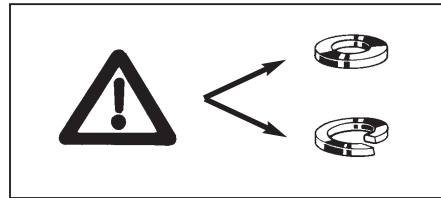
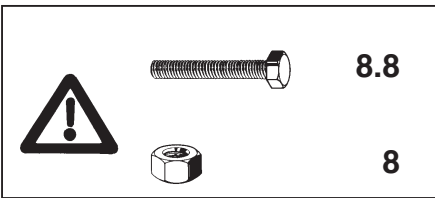
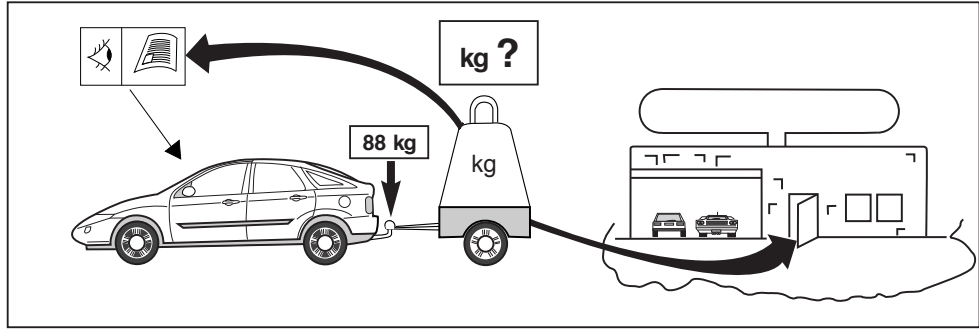

© 465970/18-06-2008/3

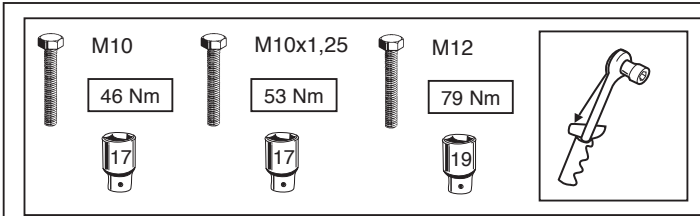

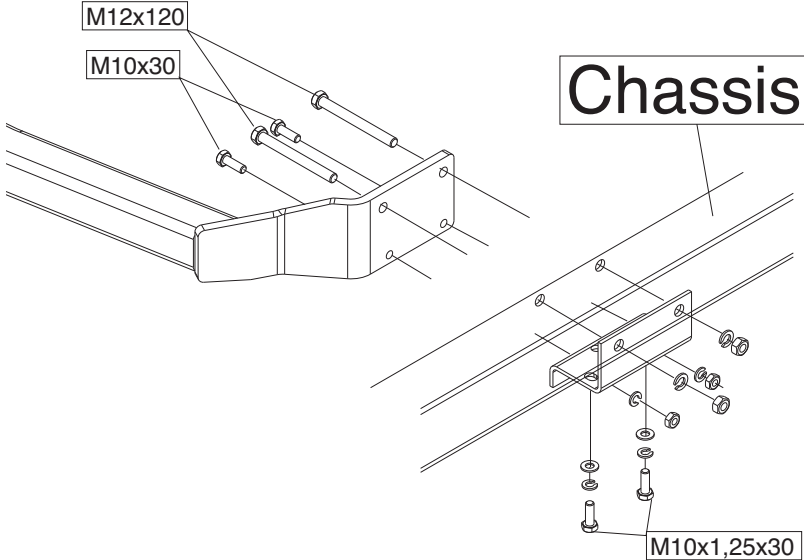
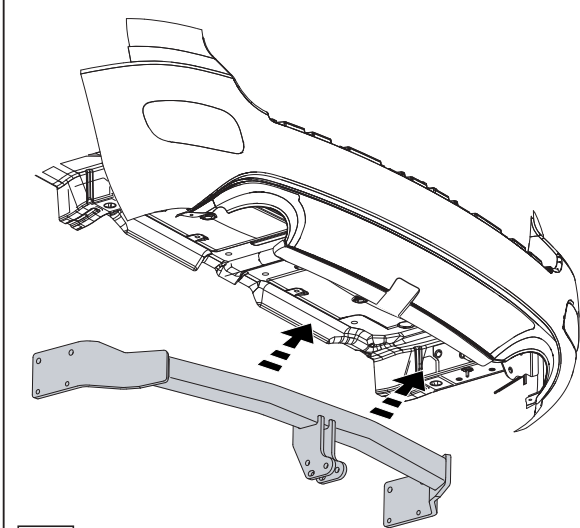
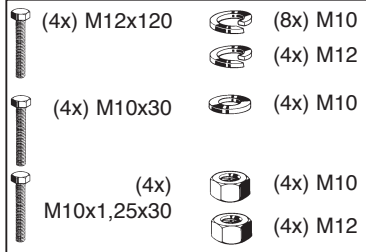

LHS + RHS





14

© 465970/18-06-2008/12

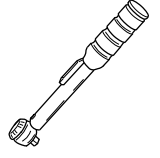

1000km



0km



M16  19 195 Nm

M12  19 79 Nm 71 Nm (with self-locking nut)

M10x1,25  17 53 Nm

M10  17 46 Nm

Torque settings for nuts and bolts (8.8)

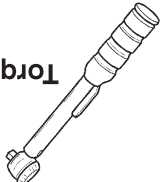

HINWEISE:

* Die für das Fahrzeug zugelassene Anhängelast ist den Fahrzeug Unterlagen zu entnehmen. Bei Änderungen des Fahrzeuggewichtes muß die höchstzulässige Anhängelast gegebenenfalls aus dem D-Wert nachgerechnet werden.

* Auskunft hierüber kann ihr Fachhändler oder der TÜV geben.

* Elektrische Anlage gemäß StVZO anbringen.

NOTE:

* Should this installation process entail the cutting of the bumper – confirmation MUST be obtained by the installation engineer of the customer's acceptance prior to completion. Brink International do not accept responsibility for any matters arising as a result of this miscommunication.

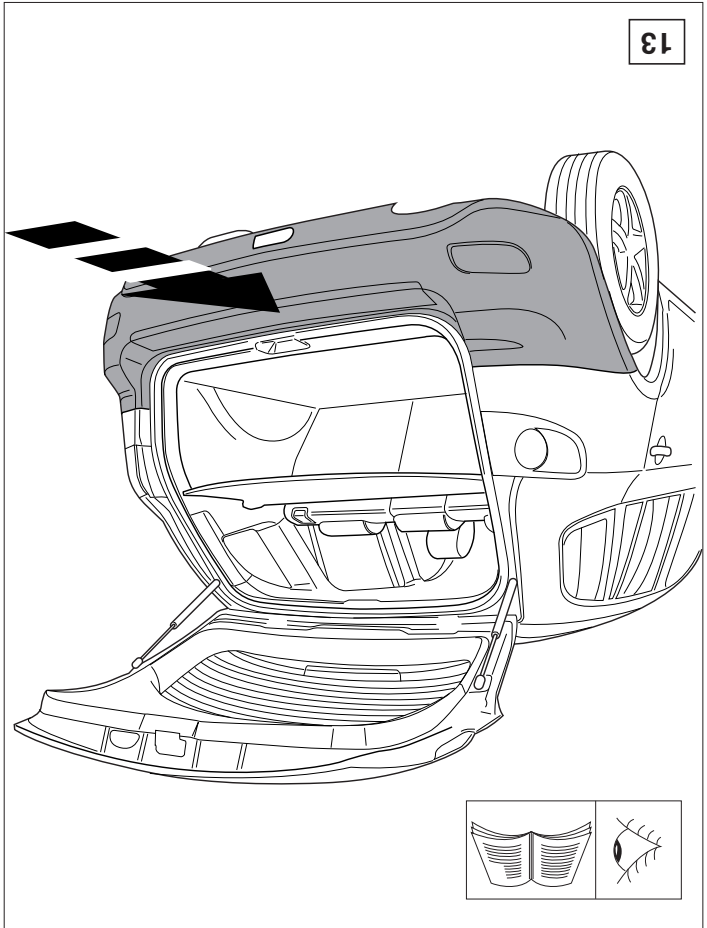

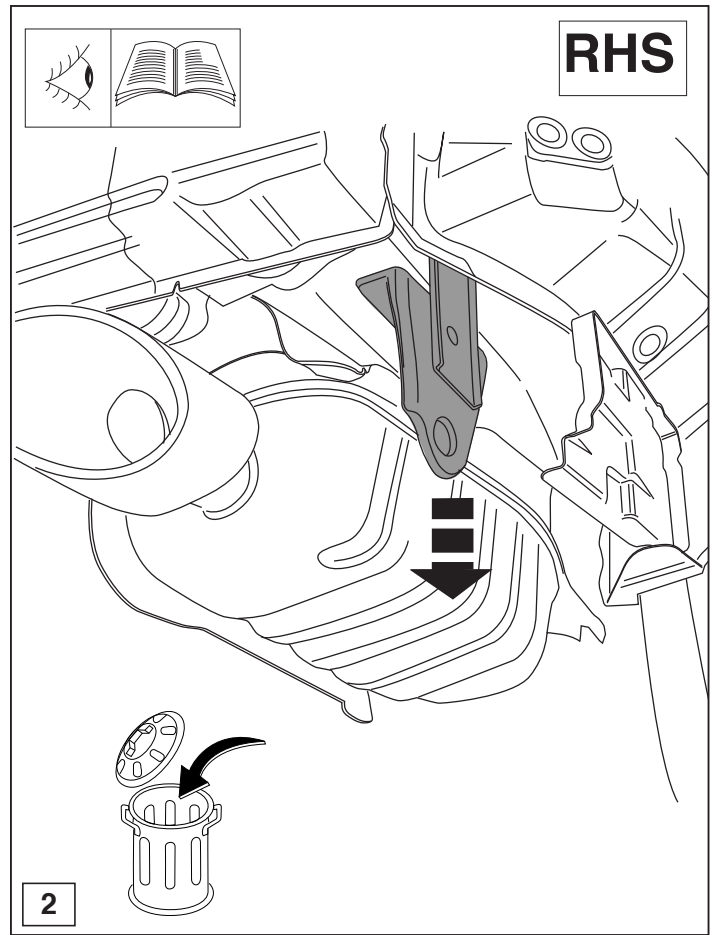
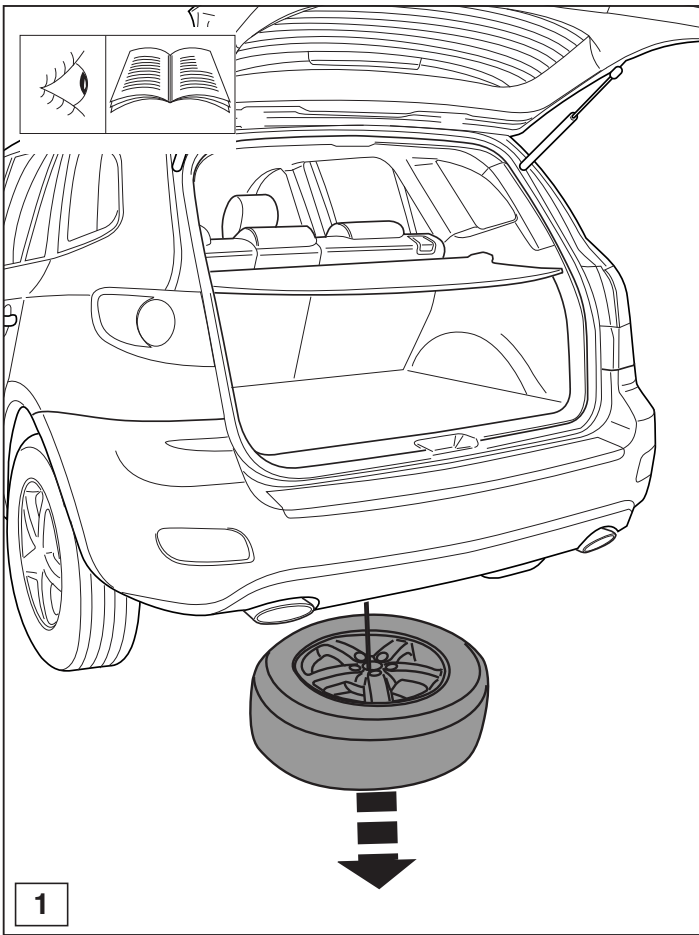

© 465970/18-06-2008/5

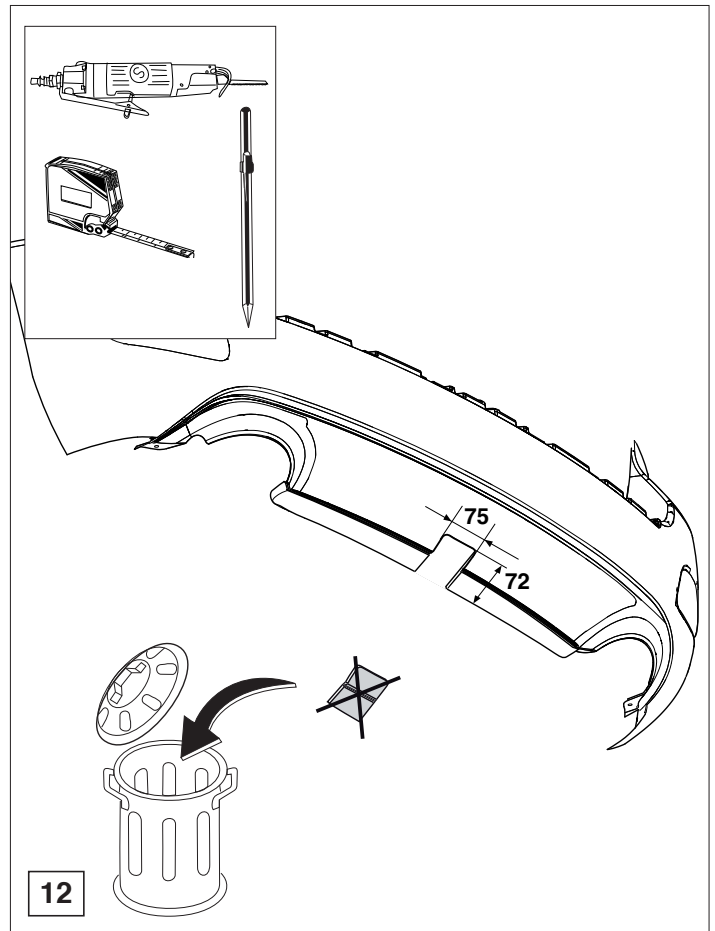
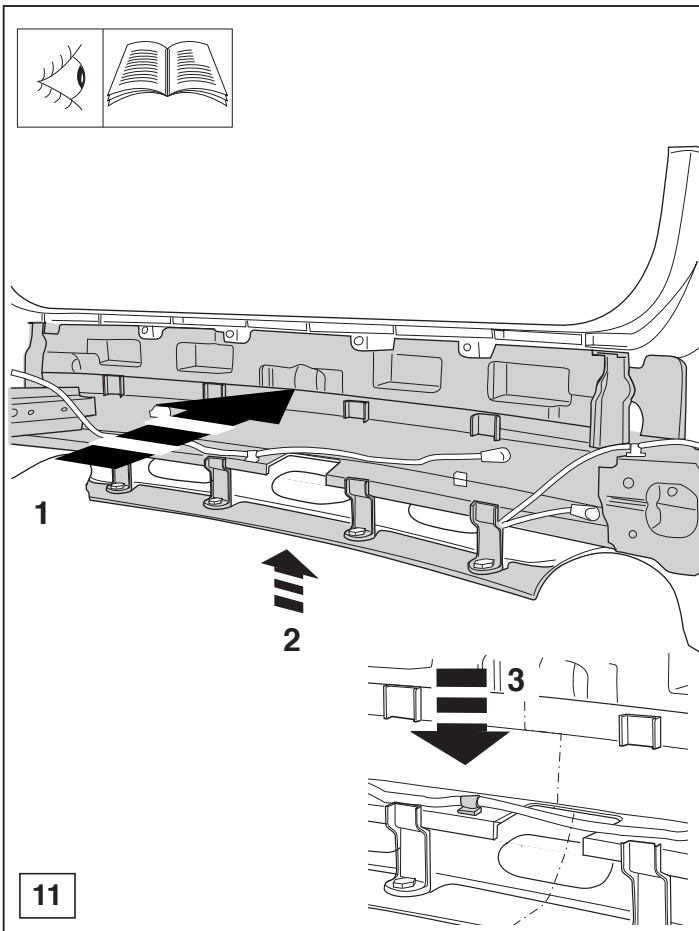

© 465970/18-06-2008/10

4

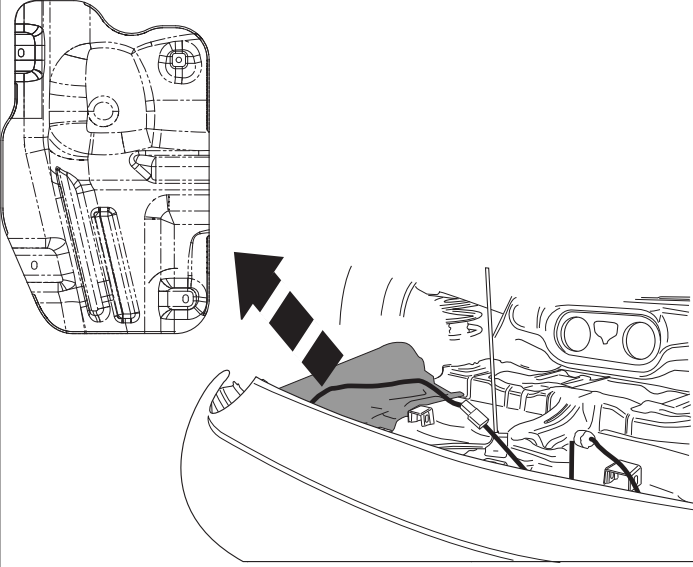

LHS + RHS



3

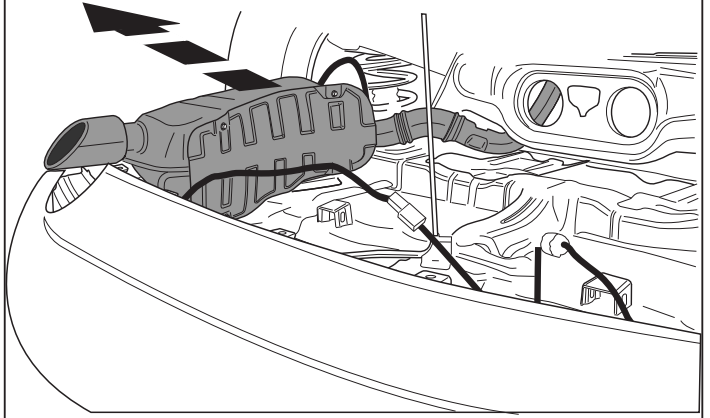

LHS + RHS

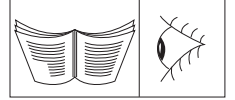

10

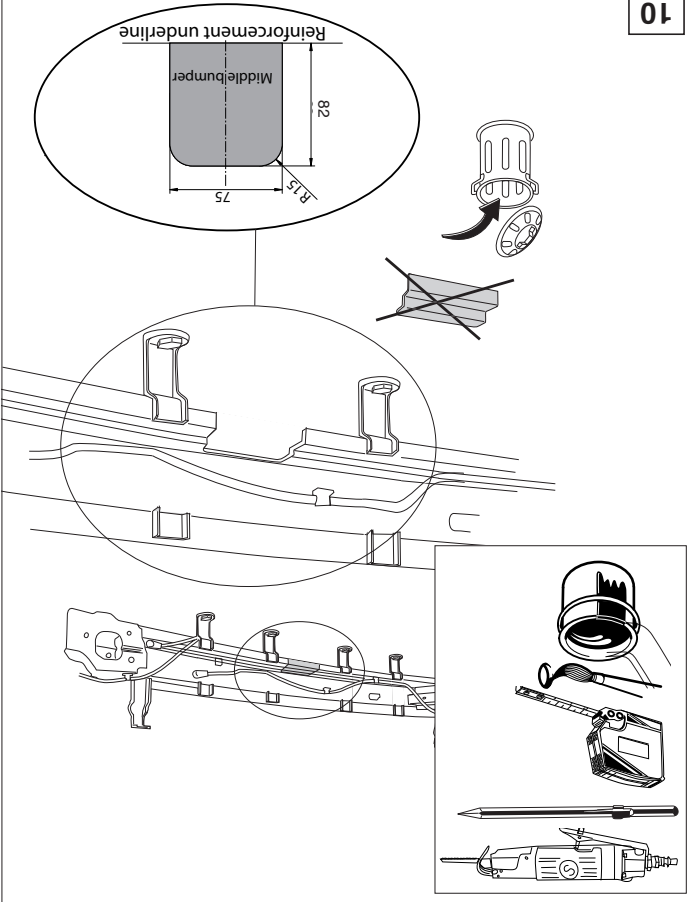

6

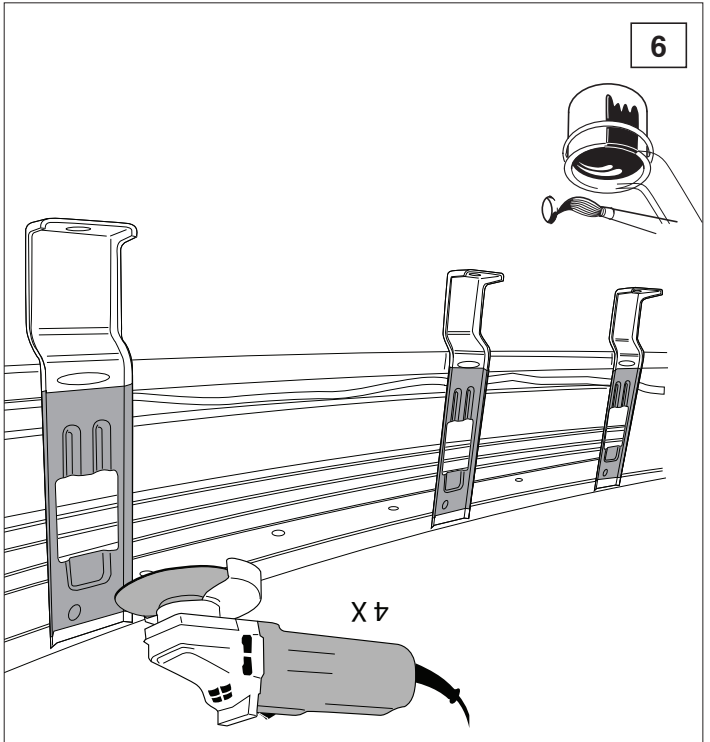

4 X

LHS + RHS

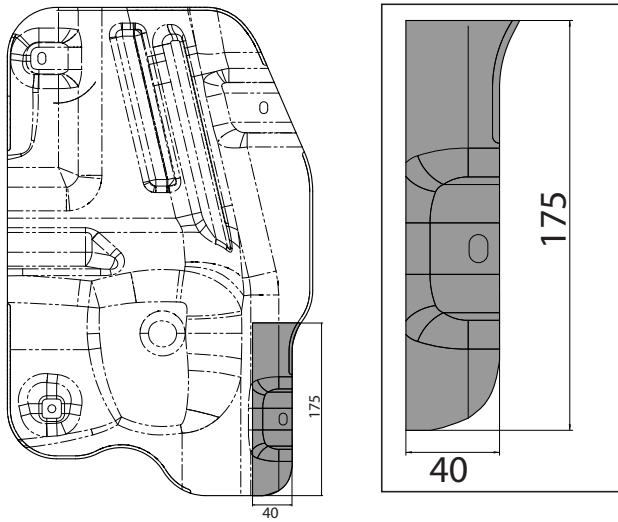
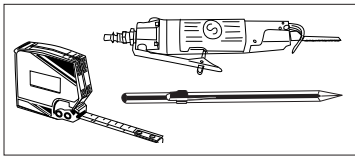

5



6

© 465970/18-06-2008/7

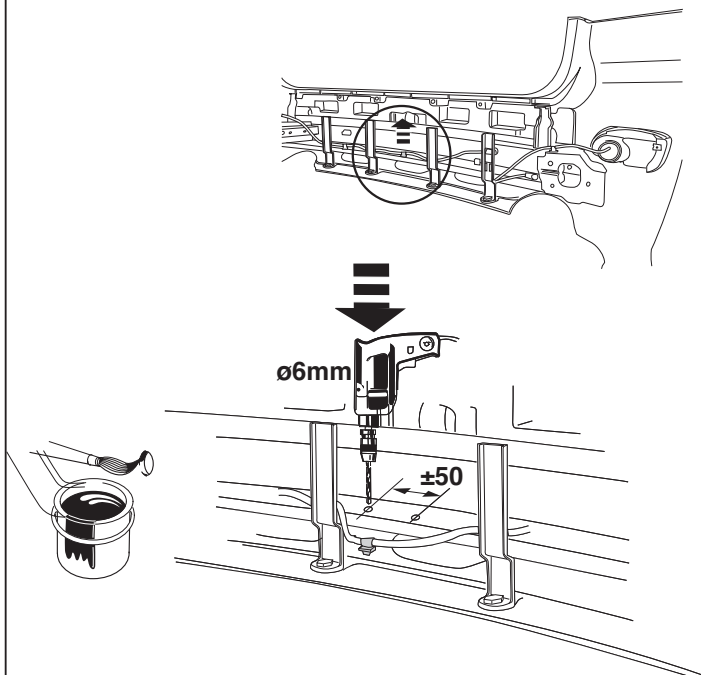
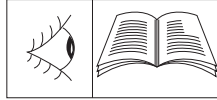

7

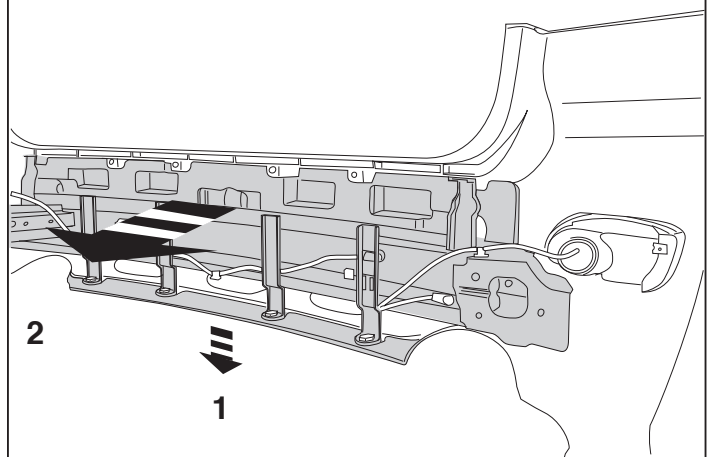

8

© 465970/18-06-2008/8