



	
0112LAE5000	0112LAE500	A	B	C	D	E	F M8 x 25	G M8 x 35	H Ø8 contact	I M8 frein	
1x	1x	1x	1x	1x	1x	1x	3x	1x	8x	4x	
0212LAE5000	0112LAE500	1x	1x	1x	1x	1x	3x	1x	8x	4x	
	2x 13						 : 4 Kg	 : 15'			

MTS Fiat SCUDO / Peugeot EXPERT / Citroën JUMPY 2007

NM échelle pliable Scudo-Expert-Jumpy 2007 - Indice 1-A
09/04/2013



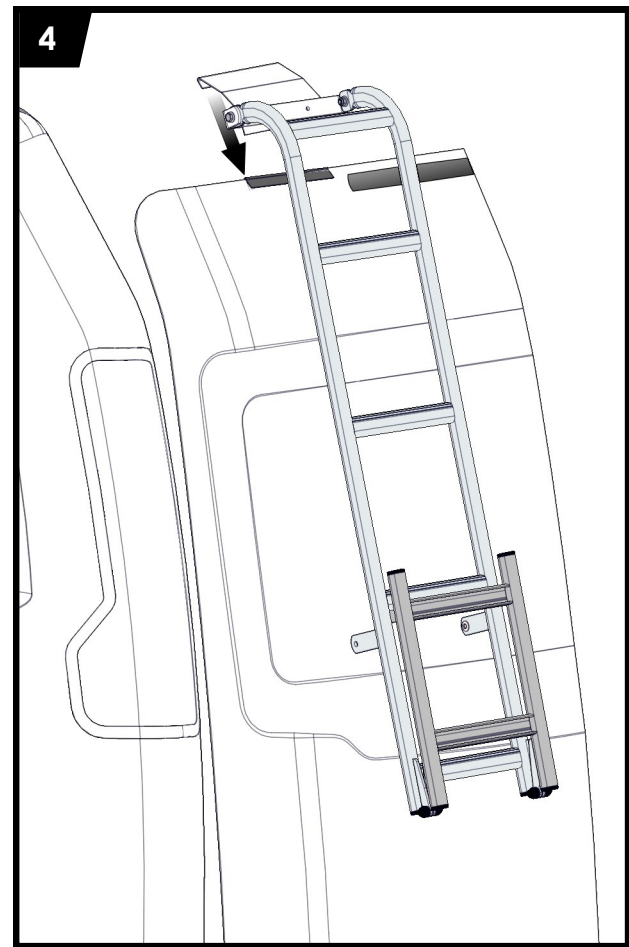
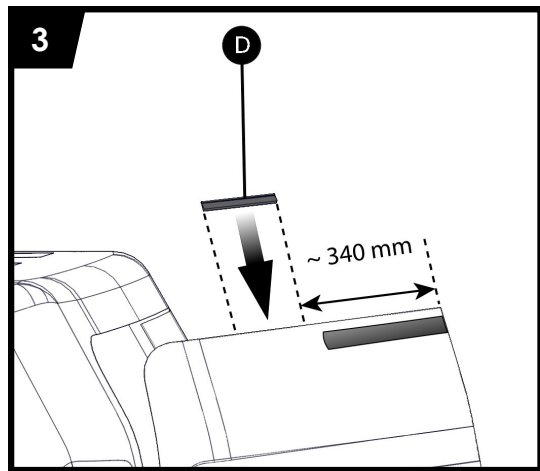
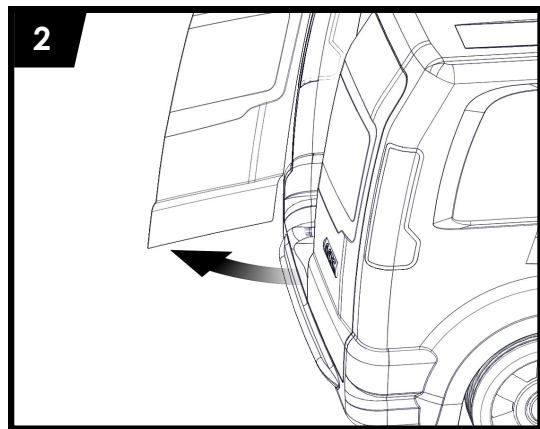
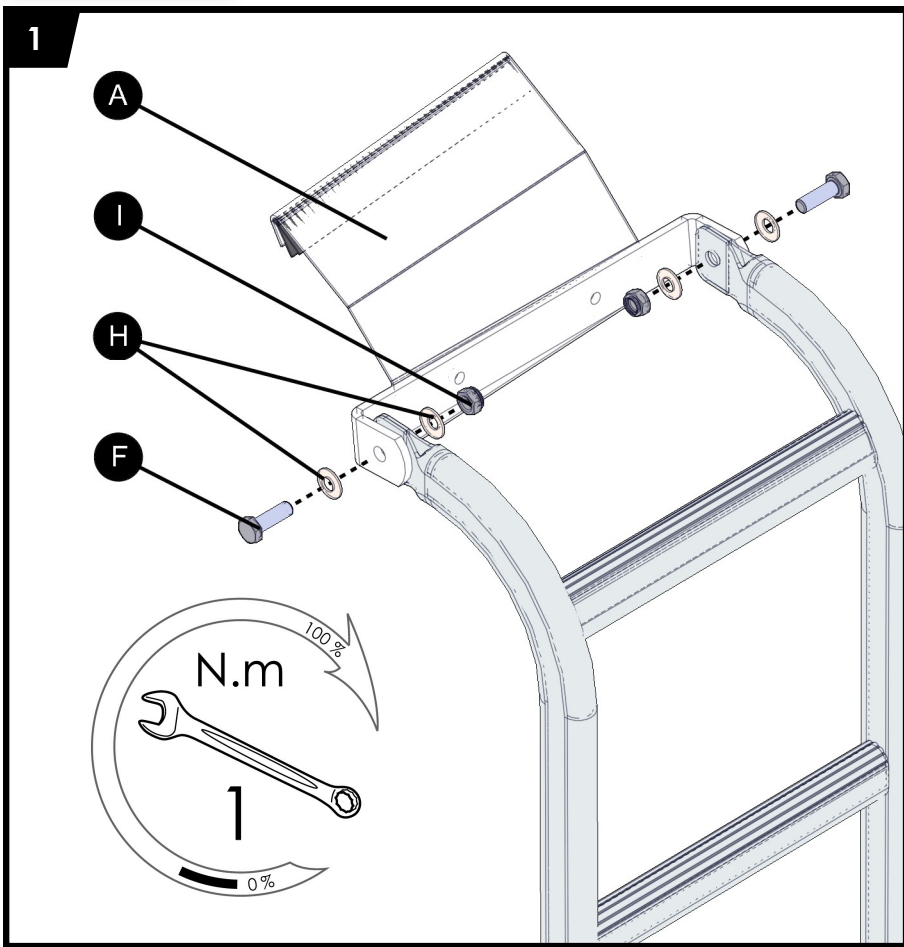
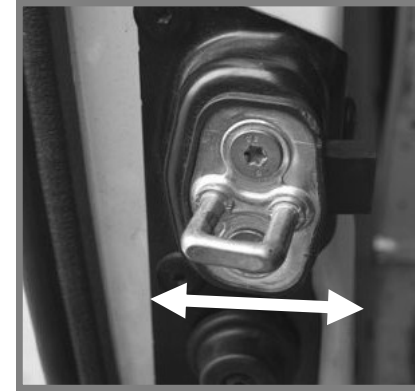
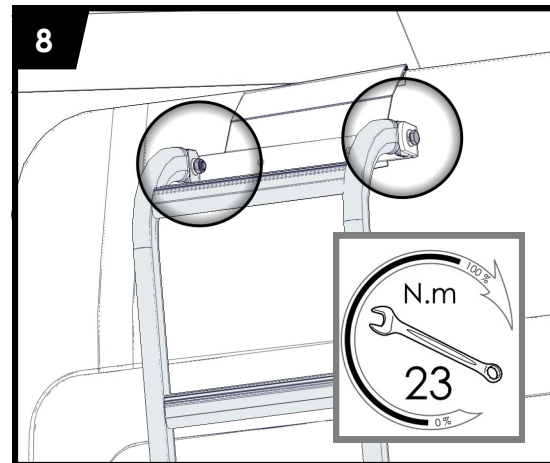
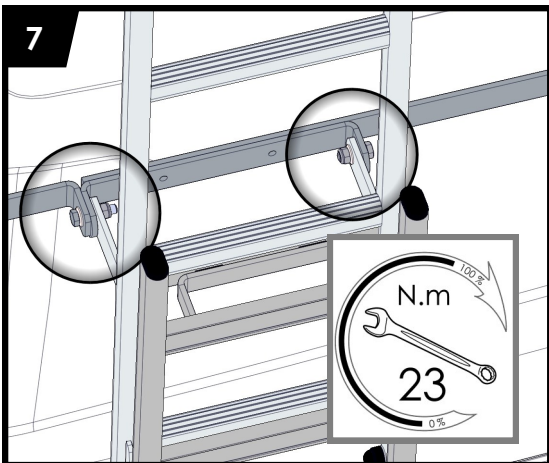
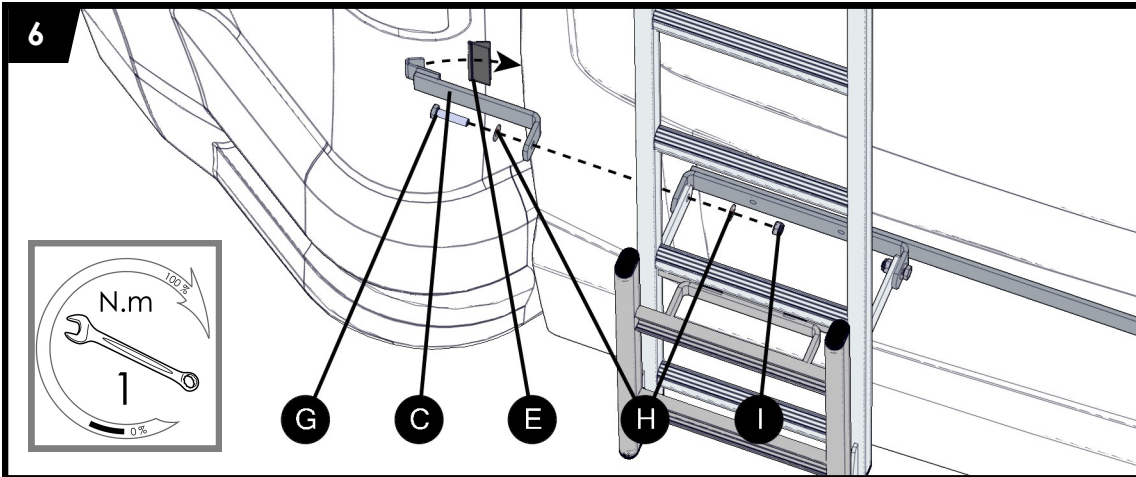
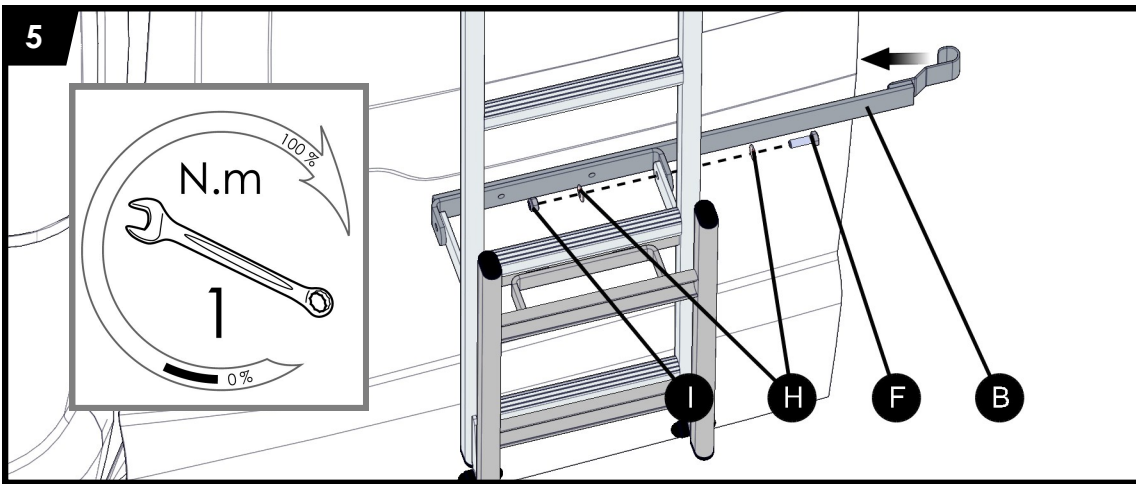

F/ Si l'étrier de l'échelle heurte la portière lors de sa fermeture, il est possible de régler la position du verrou de la portière (Photo ci-dessus) afin de lui donner plus de jeu.

EN/ If the fixing bracket of the ladder hits against the door during its closing movement, the position of the door's lock can be adjusted (see above picture) in order to get more clearance.

D/ Wenn beim Zuschlagen der Tür der Befestigungswinkel der Leiter gegen die Tür anstößt, kann die Stellung des Türschlosses eingestellt werden (siehe Bild oben), um mehr Abstand zu schaffen.

NL/ Als bij het sluiten van de deur aanstoot, kan de positie van het deurslot worden ingesteld (zie foto hierboven) om meer afstand te krijgen.

F/ L'échelle doit être pliée lorsque le véhicule circule sur la voie publique.

EN/ The ladder must be folded up when the vehicle is driven on public roads.

D/ Beim Fahren auf öffentlichen Straßen muss die Leiter zusammengeklappt werden.

NL/ Tijdens het rijden op openbare wegen moet de ladder ingeklapt worden.



2000 km
1300 Miles

