

Instructions - Instructions - Instrucciones - Anweisungen - Istruzioni - Instrukcje -
 Instructies - Instruções - Utasítások - Инструкция - Οδηγίες - Instruktioner -
 Pokyny - Instructiuni - Instrukcija - Instrukcija - Eeskiri - Instrukcie - Navodila -
 Upute - Instrukcije

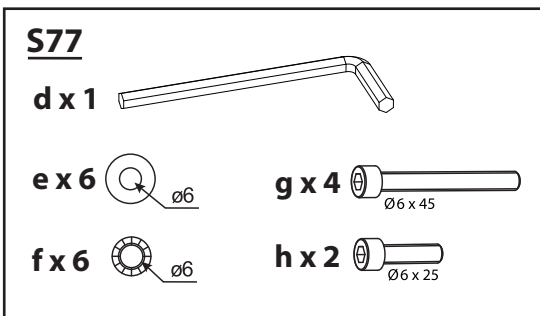

PRO RACK MEDIUM N°310

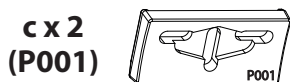
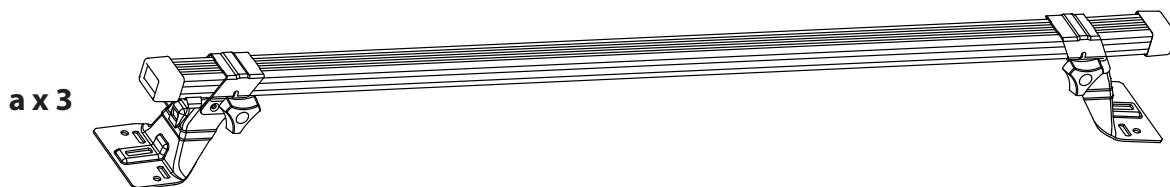

INTERNATIONAL
STANDARD

ISO 11154-1

10/1995

FRENCH
STANDARD

NFR 18-903

12/1995

100 kg

=

7,5 kg

- FRA** Garder cette notice pour les utilisations futures.
- GBR** Keep these instructions for future use.
- ESP** Guardar este manual para futuras utilizaciones.
- DEU** Die Anleitung zur späteren Benutzung aufbewahren.
- ITA** Conservare queste istruzioni per ogni ulteriore consultazione.
- POL** Zachować instrukcję w przypadku użytkowania w przyszłości.
- NLD** Bewaar deze gebruiksaanwijzing voor toekomstige raadpleging.
- PRT** Guardar este manual para as utilizações futuras.
- HUN** Őrizze meg ezt a használati utasítást későbbi felhasználás céljából.
- RUS** Сохраните эту инструкцию для дальнейшего пользования.
- GRC** Φυλάξτε αυτό το εγχειρίδιο οδηγιών για μελλοντικές χρήσεις.
- DNK** Gem denne vejledning til senere brug.
- CZE** Uschovejte návod pro pozdější použití.
- ROM** Păstrați instrucțiunile pentru consultarea lor ulterioară.
- LTU** Saglabājiet šo instrukciju turpmākai lietošanai.
- LVA** Saugokite šią instrukciją, kad ateiťtyje galėtumėte ja pasinaudoti.
- EST** Hoidke need juhised edaspidiseks kasutuseks alles.
- SVK** Tento návod si uchovajte pre ďalšie použitie.
- SVN** Sačuvajte ovaj priručnik za buduću upotrebu.
- HRV** Čuvati ove upute za daljnju uporabu.
- SRB** Čuvajte instrukcije za dalju upotrebu.









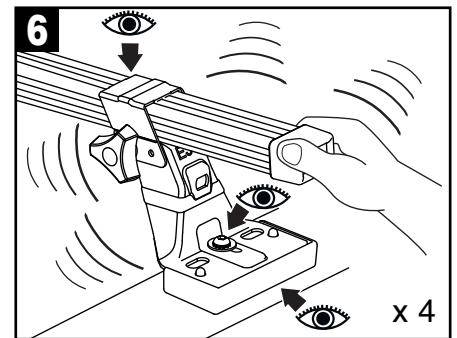
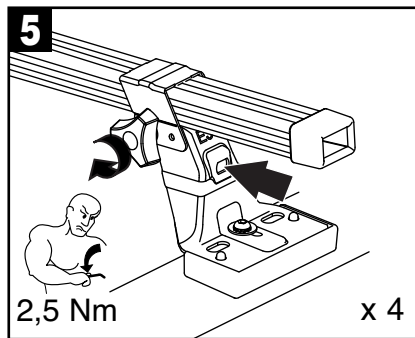
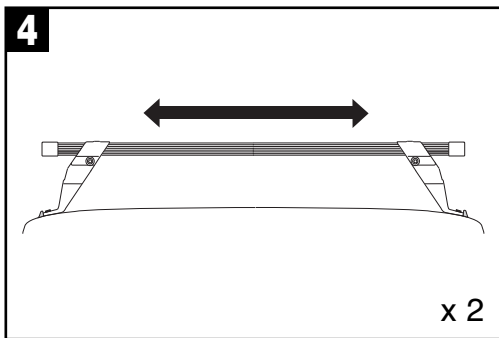
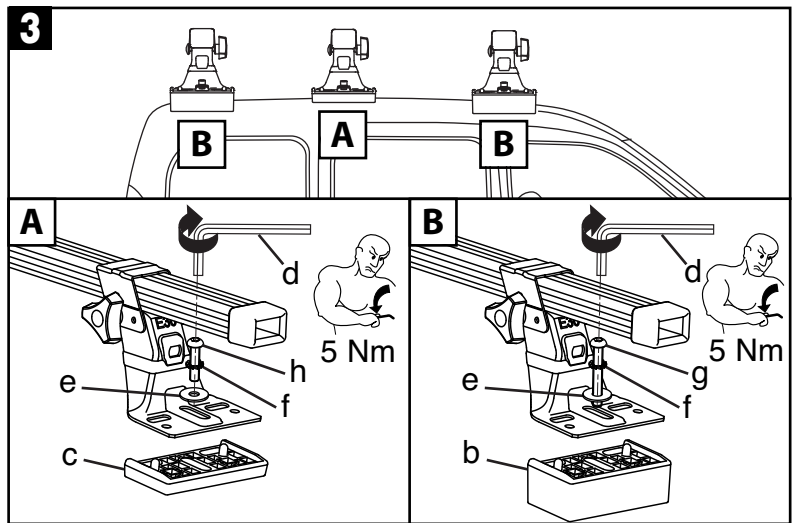
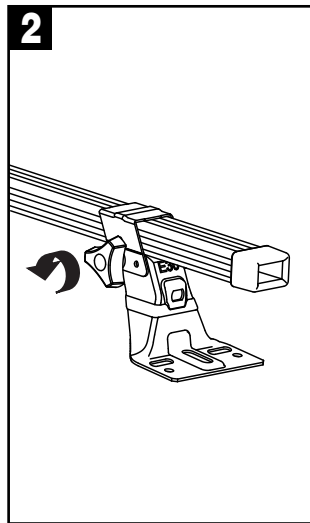
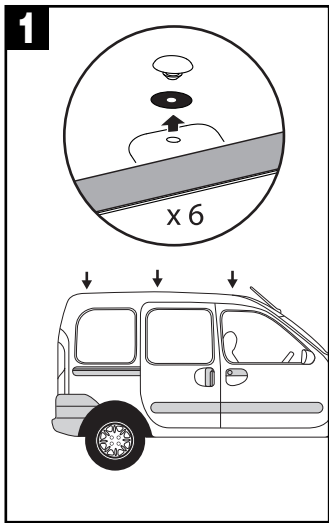



**AUTOMAXI
INTERNATIONAL**

Z.I Nord - 24 Rue Claude Bernard - CS 61768
 35417 Saint Malo Cedex - France
 Tél : 33 (0) 2 99 21 12 70
 Fax : 33 (0) 2 99 21 12 71
www.automaxi.fr

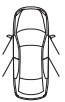
**Montage sur véhicule - Fitting on vehicles - Colocación en vehículos -
 Montagen auf Fahrzeugen - Montaggio su veicoli - Montowanie na pojazdach -
 Montage op voertuigen - Montagens em veículos - Felszerelés gépjárműre -
 Монтаж на автомобиль - Τοποθέτηση στο όχημα - Montage på køretøjer -
 Montáž na vozidlo - Montaj pe vehicul - Montavimas ant transporto priemonės -
 Transporta līdzekļa montāža - Sõidukitele paigaldamine - Upevnenie na vozidlá -
 Oprema na vozilih - Ugradnja na vozilima - Ugradnja na vozilima**



**Les barres de toit ne doivent pas être utilisées sur des véhicules autres que spécifiés -
 Appropriate for vehicle - Verwenden sie fur fahrzeug - Serve a veiculo -
 Convieni para vehiculo - Pasujena samochod - Geschikt voor voertuig -
 Appropriare per vehicule - Megfelelő gépjármű - Подходит для автомобилей -
 Για το οχημα para - Egnnet til køretøjer - Vhodné do vozidel -
 Convenabil pentru vehicul - Tinka transporto priemonei - Piemērots
 transportlīdzekļiem - Sobib sõidukile - Vhodné pre vozidlo -
 Primerno za vozilo - Podesno za vozilo - Podesno za vozilo**

   	   	   
FIAT DOBLO 3/5 ⁽²⁾ 01→09 100		

(2) = Véhicule sans barres longitudinales d'origine - Vehicle without original longitudinal bars - Fahrzeuge ohne original-dachreling - Veicoli senza barre longitudinali originali - Vehículo sin barras longitudinales de origen - Samochód bez oryginalnych relingów - Voertuig zonder originele longitudinale stangen - Veículo sem barras longitudinais de origem - Gyárilag hosszirányú rudak nélkül szerelt gépjármű - Автомобиль без продольных дуг, предусмотренными моделью - Όχημα χωρίς διαμήκεις μπάρες από εργοστασιακή κατασκευή - Køretøj uden originale bjælker på langs - Vozidlo bez původních postranních tyčí - Vehicul fără bare longitudinale originale - Transporto priemonė be originalių lonžeronų - Satiksmes līdzeklis bez oriģinālā gareniskā stienstieģrojuma - Sõidukid ilma esialgsете pikivarrasteta - Vozidlo bez pôvodných pozdĺžnych lišt. - Vozilo brez originalnih vzdolžnih drogov - Vozilo bez originalnih uzdužnih šipki - Vozilo bez originalnih uzdužnih šipki.